

F5 BIG-IP

LTM

Lab Manual

Redouane MEDDANE



Table of Contents :

Lab 1: F5 BIG-IP Installation.....	4
Lab 2: Activation License.....	7
Lab 3: Setup Utility.....	14
Lab 4: Configuration Backup.....	20
Lab 5: Traffic Processing Pool and Virtual Server.....	22
Lab 6: Load Balancing.....	33
Lab 7: Monitors.....	41
Lab 8: Profiles.....	51
Lab 9: Client SSL.....	57
Lab 10: iRules.....	66
Lab 11: SNAT.....	77

Lab Topology

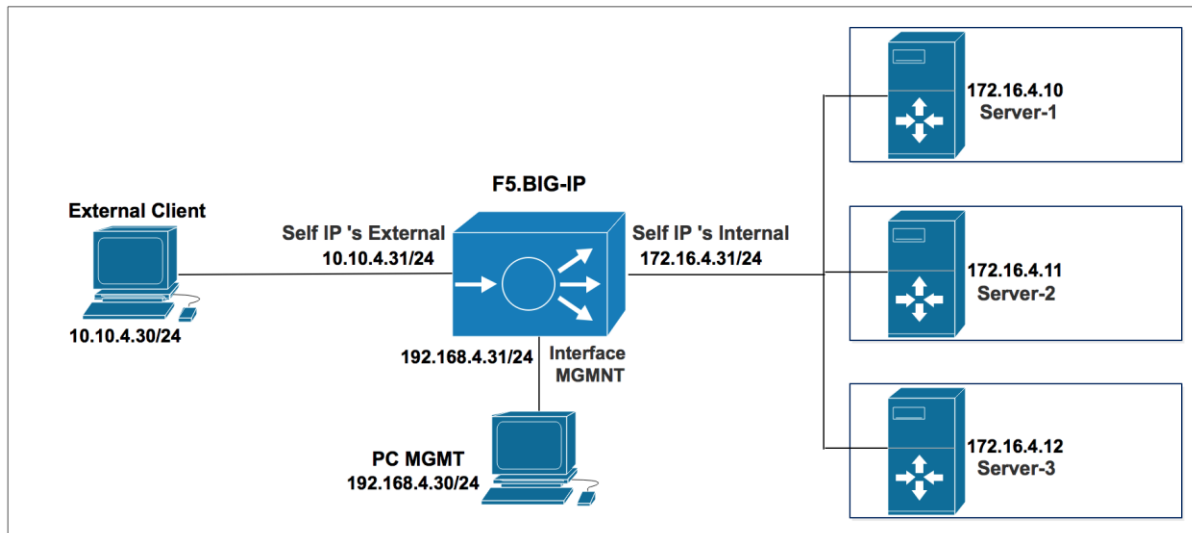

Note: I am using Cisco Routers as **HTTP HTTPS** and **SSH** Server

Lab 1: F5 BIG-IP Installation

Step 1

Log in to the CLI using the default user account. Use **root** as username and **default** as password.

```
BIG-IP 11.3.0 Build 39.0
Kernel 2.6.32-220.el6.f5.x86_64 on an x86_64
localhost login: root
Password:
Last login: Thu Apr 20 13:00:54 on tty1

[root@localhost:NO LICENSE] config #
[root@localhost:NO LICENSE] config # _
```

Step 2

Issue the **config** command.

Step 3

Once you get the prompt as shown below, click **OK**.

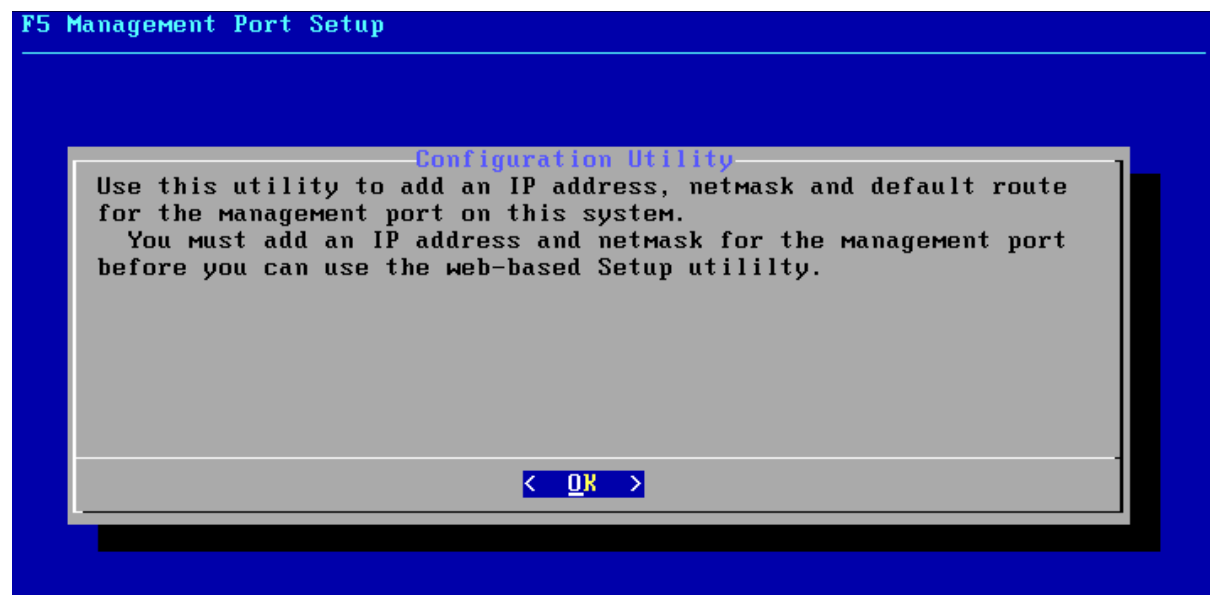

The next prompt will ask you if you want to use the automatic configuration, choose **No**.

Configure IP Address

Use automatic configuration of IP address?

Current IP Address: 192.168.1.254
Current Netmask: 255.255.255.0
Default Route: 192.168.1.1

< Yes > **< No >**

Step 4

Enter desired IP address for the management interface and click **OK**.

Configure IP Address

IP Address

172.16.1.254

< OK > **< Cancel >**

Step 5

Enter desired subnet mask for the management interface and click **OK**.

Configure IP Address

Netmask

255.255.255.0

Step 6

To access the BIG-IP from any network, configure a default gateway, click **Yes**.

You will be prompted to enter the IP address of the default gateway and click **OK**.

Configure IP Address

Management Route

172.16.1.1

Step 7

Confirm the management IP address changes by clicking **Yes**

Accept these settings?

IP Address: 172.16.1.254

Netmask: 255.255.255.0

Default Route: 172.16.1.1

< Yes >

< No >

Lab 2: Activation License

To access the BIG-IP Configuration Utility, open a web browser and enter the URL <https://172.16.1.254>. To log in, use the default username and password, which is **admin/admin**.

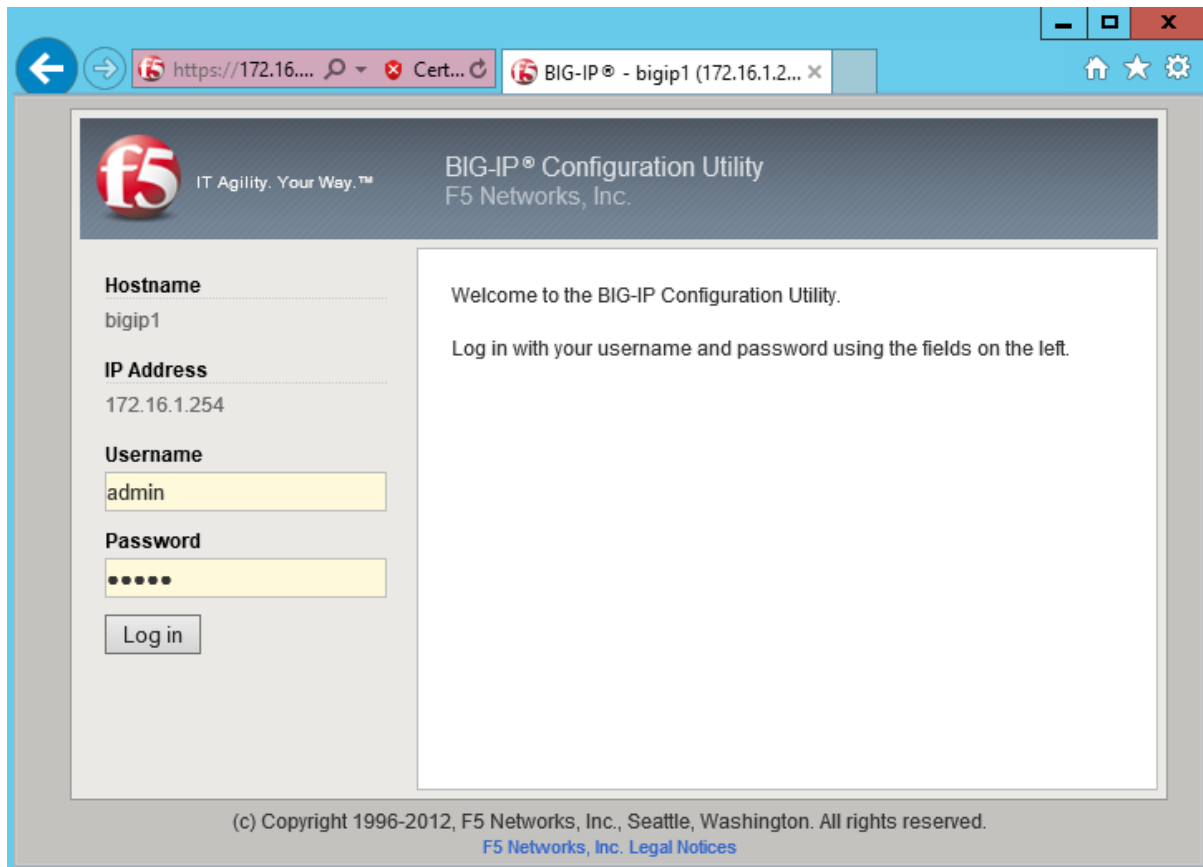

To start the Setup Utility wizard, click **Next** to continue.

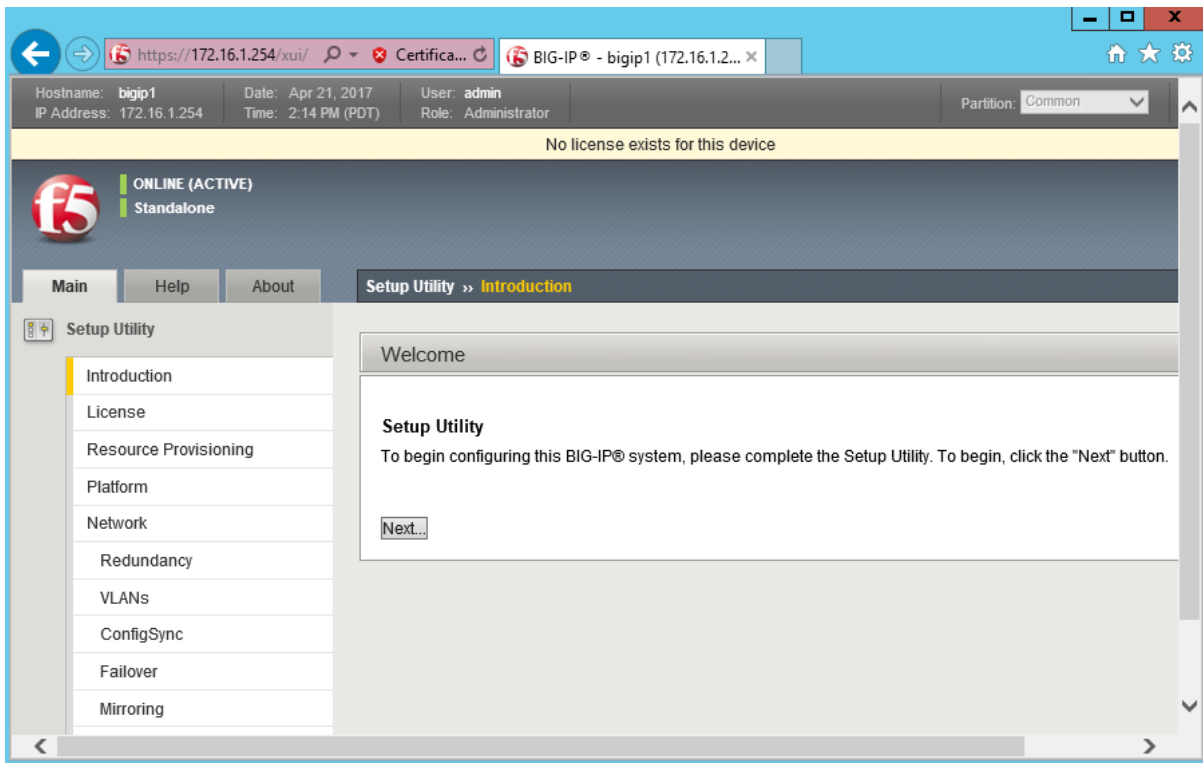

You will be presented with a screen that asks you to activate the BIG-IP LTM license. Click **Activate**.

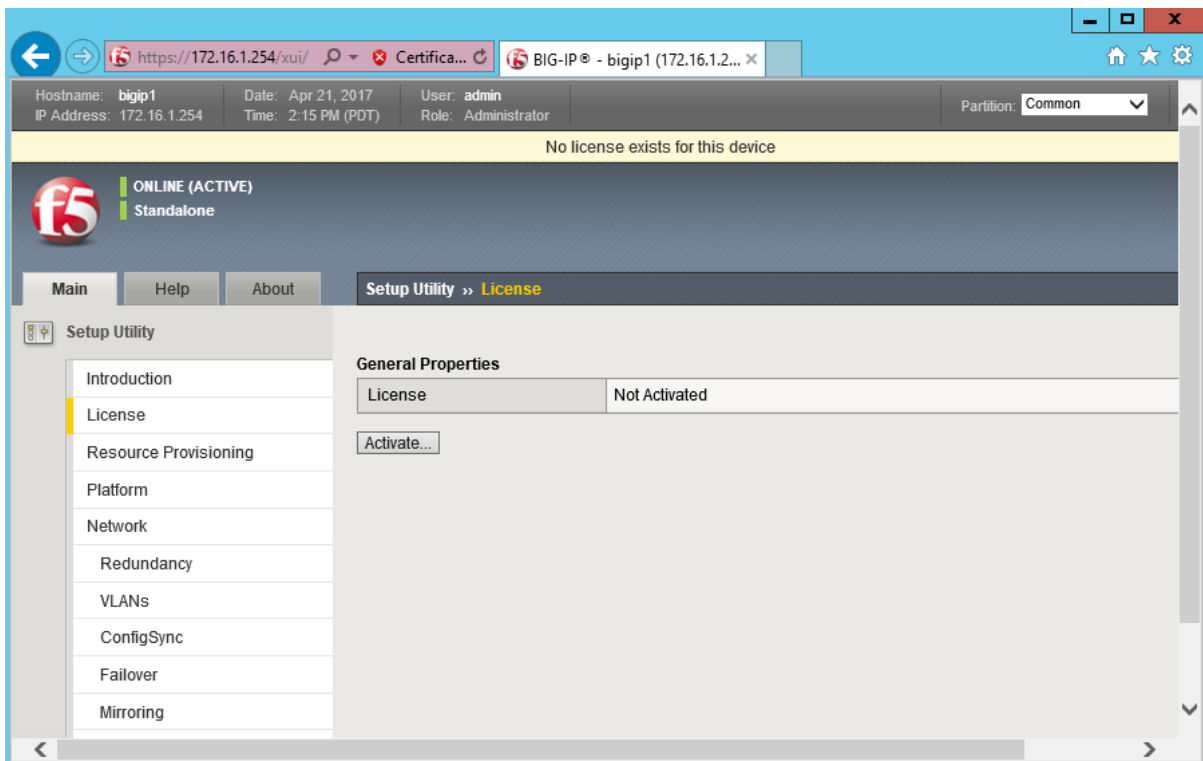

Enter the license key that you received from F5 Networks. Choose the activation method – automatic and manual.

Automatic method requires the Internet access from the management interface. The manual method is used when the management interface does not have access to the Internet.

In this case, choose the manual method, enter the license key and click **Next** to continue.

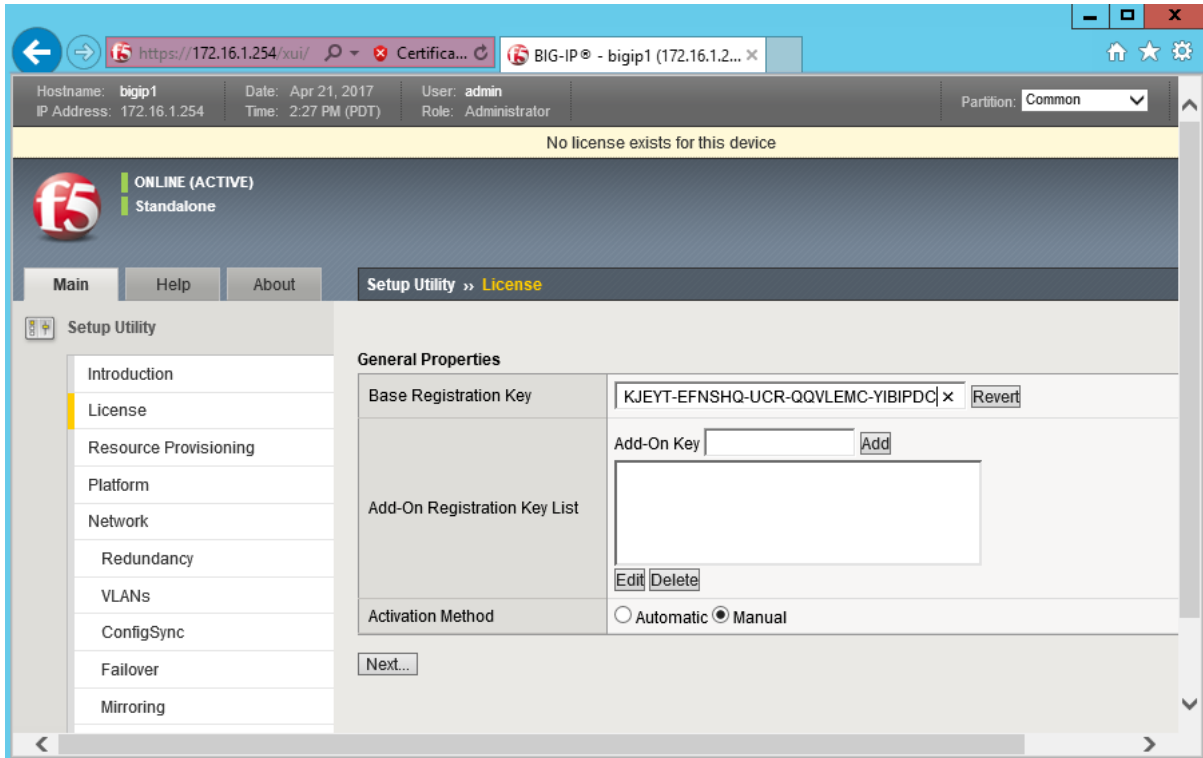

Copy all text found in the **dossier** box.

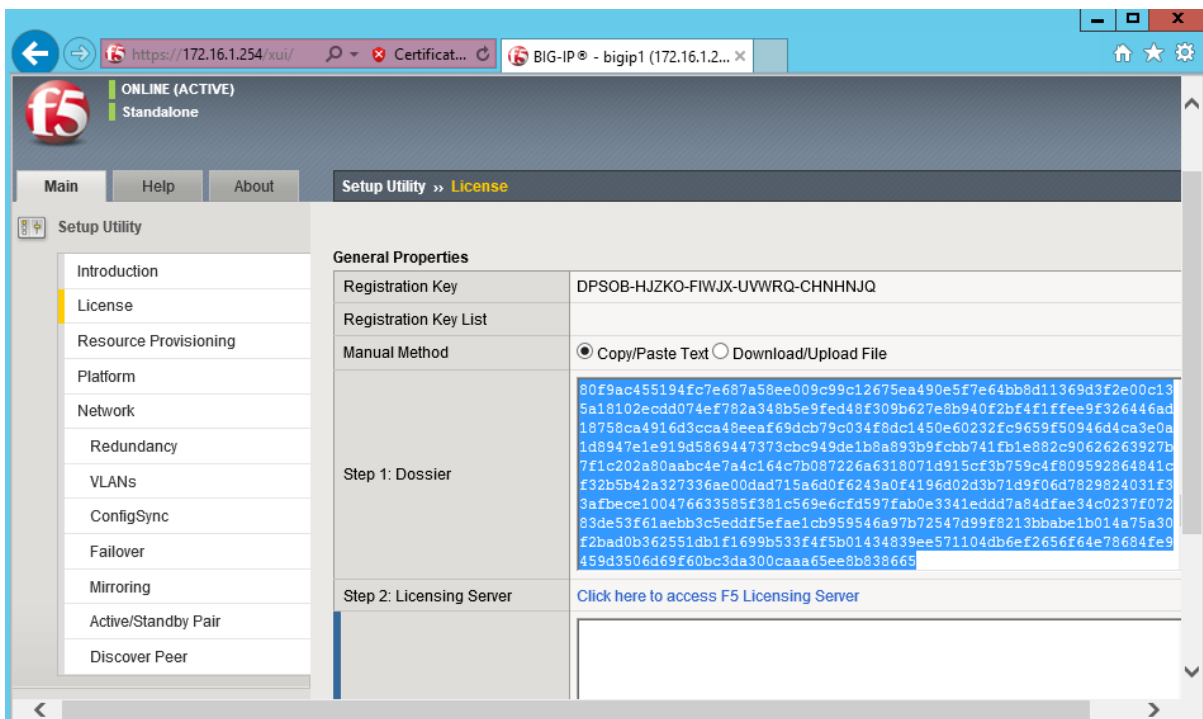

Go to the F5's licensing site at <https://activate.f5.com/license/dossier.jsp> . Paste the dossier to the box. Alternatively, upload the dossier file. Click **Next** to continue.

To activate your product you will need your product dossier.

Enter Your Dossier

```
0518311dfe2bb097c481d58b6d35fa09e2c5b8c1913c464b3ec2c96d622814be09cc4415a955d67b0c
5d0a59a0eb408408af084361362237a7e701d26aed40310fbefe74fe212916f7dbd25e2e0ea321bcbc
655bdc3cf8b32077e4eb7d0a98e3fea4faccaca6cce9ffb4e96c7f811e94616078b7f9f79aeba87e64
5098fd68958934147a864b6b139188a7cb43beebafd00db9823a681128b823b27454eb5cfbb8aa4049
143da0d26b239f3daf5f4fa6aba32b5338c78fd77d634a29735964d3fad506ed674e36139938c87fbe
4339e8ef535def140d0a8b185f0717390e8c7c759b9fd2ea8ec2704c712f2846278bc4ddeab66354fe
8ee4d7b2ce18449f6da39e02a33cc694464339bc0973ee939bd7185a67e1f7823eee9d88e881c5f3d5
7c3fdfe5b26cf7152c3936e6dd36edfa07d6d268110d8b8f3469b7e809ecf5773b1cc9145a08a9ee8b
64f832fd1ae2957b640f668a04b873e3394a1bb47da0abac95b0d69e842299f7f4a57aa4499c532616
de959d2e70cc9a9386943f538d33cd0b5a167bebf856efac8719d81f382bafac77605cd4ae3d9ee8
c8ae13120de1b0cd232eb0394447205e474875963209e17bbf436643ba8e6754d4f83640622378d0da
342ee1e1b004e6355125f8d34e1791d9438e60109d999fb16a4b2922f640cc5871402fba0c30df003b
43cd2ab25aa57605d193c49b4f8694d61b09fca478706f516248249a37399390522c5b91ed30727526
cc469027ae28880f9ac455194fc7e687a58ee009c99c12675ea490e5f7e64bb8d11369d3f2e00c135a
18102ecdd074ef782a348b5e9fed48f309b627e8b940f2bf4f1ffee9f326446ad18758ca4916d3cca4
8eeaf69dcb79c034f8dc1450e60232fc9659f50946d4ca3e0a1d8947e1e919d5869447373c949de1
b8a893b9fcb741fb1e882c90626263927b7f1c202a80aabc4e7a4c164c7b087226a6318071d915cf3
b759c4f809592864841cf32b5b42a327336ae00dad715a6d0f6243a0f4196d02d3b71d9f06d7829824
031f33afbece100476633585f381c569e6cfd597fab0e3341eddd7a84dfae34c0237f07283de53f61a
ebb3c5eddf5efae1cb959546a97b72547d99f8213bbabe1b014a75a30f2bad0b362551db1f1699b533
f4f5b01434839ee571104db6ef2656f64e78684fe9459d3506d69f60bc3da300caaa65ee8b838665
```

or

Select Your Dossier File

Parcourir... Aucun fichier sélectionné.

Next

Read and accept the F5 Networks' EULA. Click the check box to accept the EULA and click **Next**.

Activate F5 Product

Step 2: Accept User Legal Agreement

```
END USER LICENSE AGREEMENT
DOC-0355-08

IMPORTANT - READ BEFORE INSTALLING OR OPERATING THIS PRODUCT
LICENSEE ("LICENSEE") AGREES TO BE BOUND BY THE TERMS OF THIS
AGREEMENT BY INSTALLING, HAVING INSTALLED, COPYING, OR OTHERWISE
USING THE PRODUCT. IF LICENSEE DOES NOT AGREE, DO NOT INSTALL OR
USE THE PRODUCT.

1. Scope. This End User License Agreement ("License") applies to the
software product ("Software") Licensee has licensed from F5. All
references to "F5" in this License will be deemed to be a reference to
the applicable F5 entity as follows: (i) if Licensee's primary place of
business is located in the European Economic Area, the Middle East or
Africa ("EMEA"), the F5 entity is F5 Networks Ltd.; (ii) if Licensee's
primary place of business is located in the Asia-Pacific region,
excluding Japan, India and Taiwan ("APAC"), the F5 entity is F5
Networks Singapore Pte Ltd; and (iii) if Licensee's primary place of
business is located in Japan, India, Taiwan or a region outside of EMEA
or APAC, the F5 entity is F5 Networks, Inc. Certain Software is
licensed for use in conjunction with F5 hardware which together with
```

I have read and agree to the terms of this license

Next

Copy the license information for your BIG-IP LTM. Alternatively, you can download the license file.

Cut and paste your license key from the form below, or click the download button to download a copy of the license file.

Download license

```
#
Auth vers :          5b
#
#
#   BIG-IP System License Key File
#   DO NOT EDIT THIS FILE!!
#
#   Install this file as "/config/bigip.license".
#
#   Contact information in file /CONTACTS
#
```

Paste the license information to **License** section of the Setup utility, click **Next**. You will then be presented with a screen as shown below. Wait one moment. Click **continue** button.

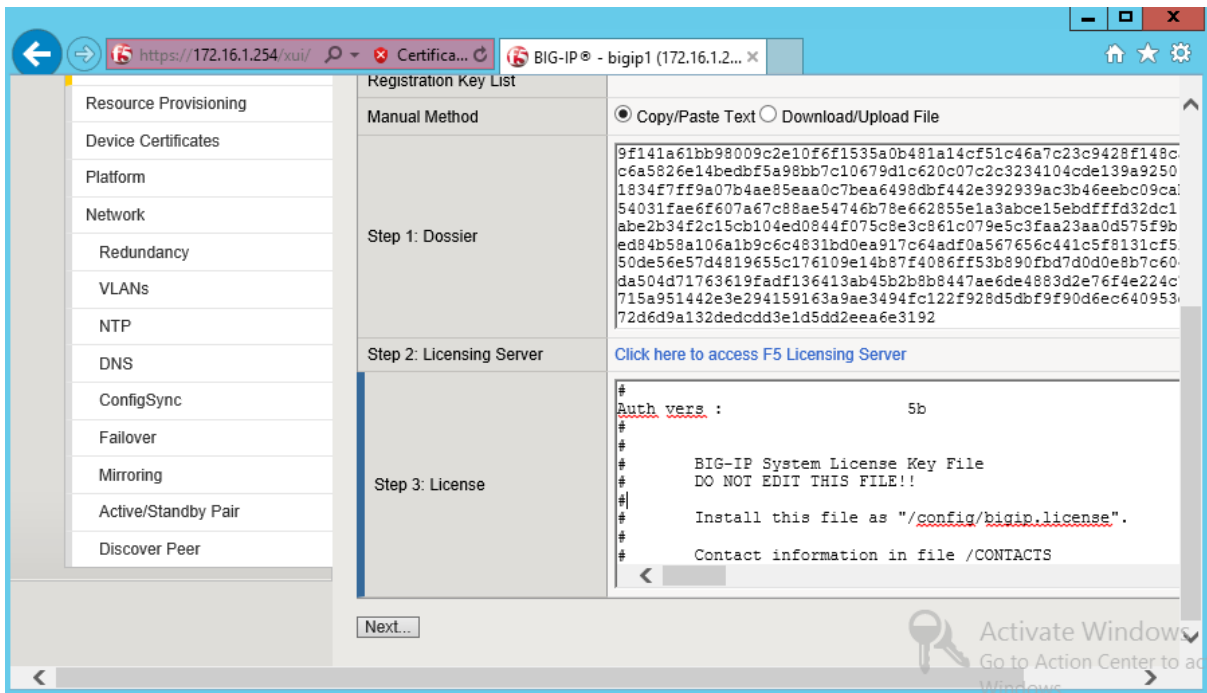

You can see that the LTM license is activated.

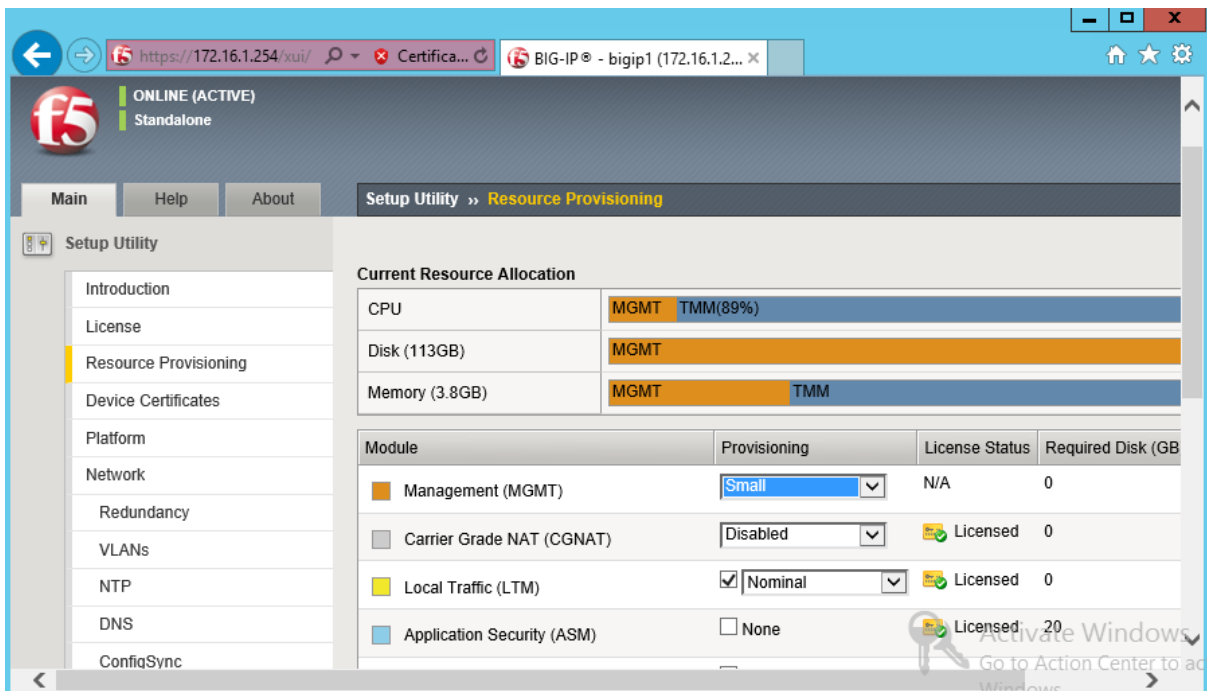

Click **Next**.

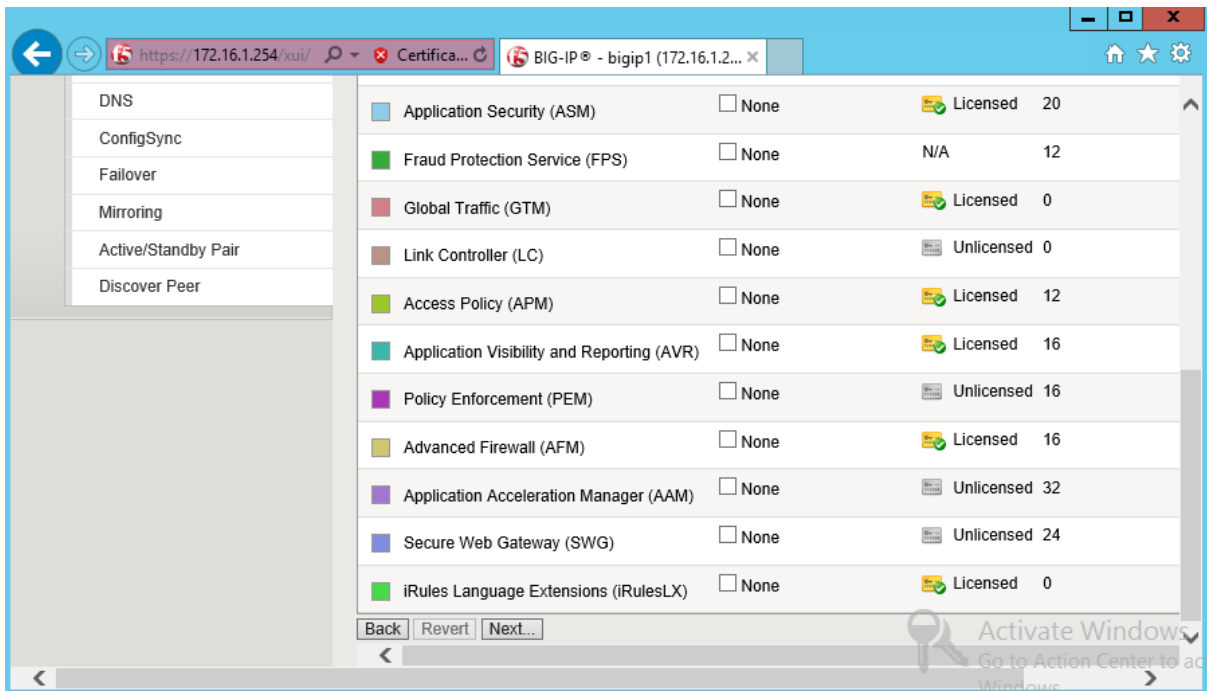

The setup utility wizard allows you to make configuration to the management interface, 192.168.4.31 in this case, host name, time zone, user account passwords for CLI and GUI access. The SSH IP Allow section acts as an ACL to allow certain IP addresses and/or ranges the BIG-IP access. Once you make changes to the account passwords, you will be logged out and need to log back in using the new IP address and the new accounts. Click **Next**.

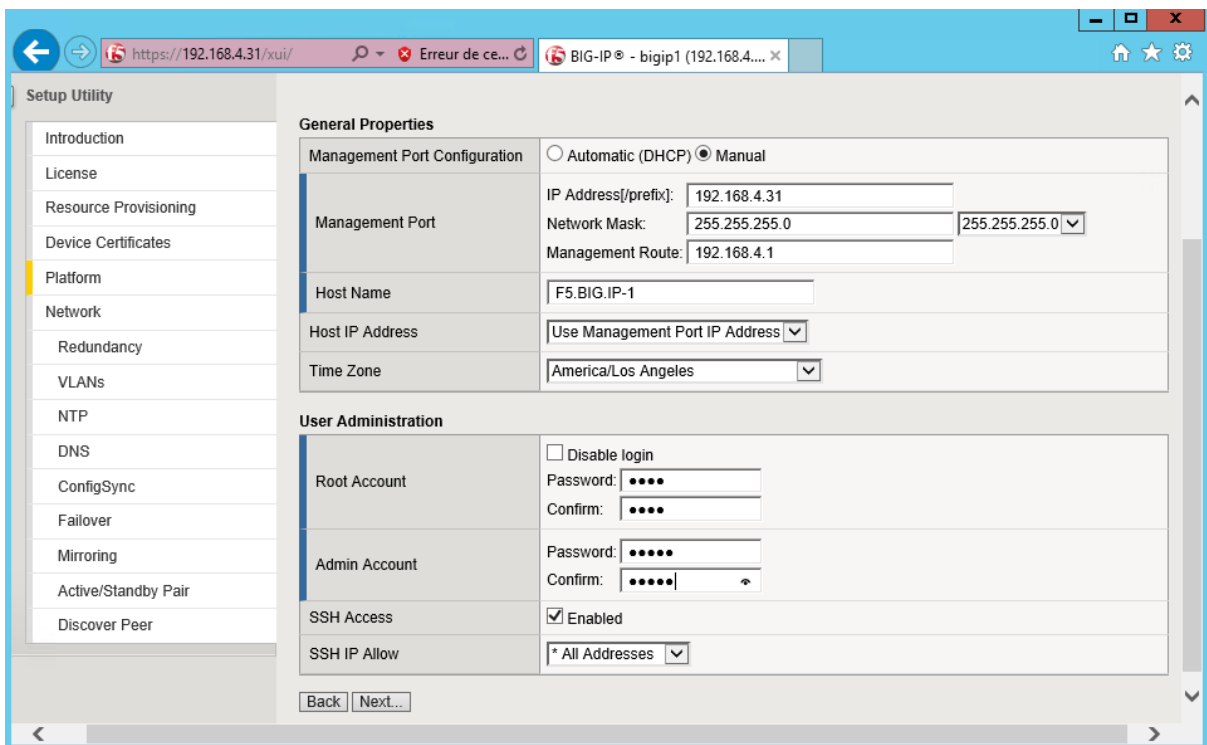

Lab 3: Setup Utility

Network Configuration

Once you log back in, you will be in the network section. You have ability to continue the setup utility to configure internal (real servers) and external (client side) vlans and associated interfaces and self IPs.

(Self IPs are the equivalent of SVI IP in Cisco switching)

Click **Next**.

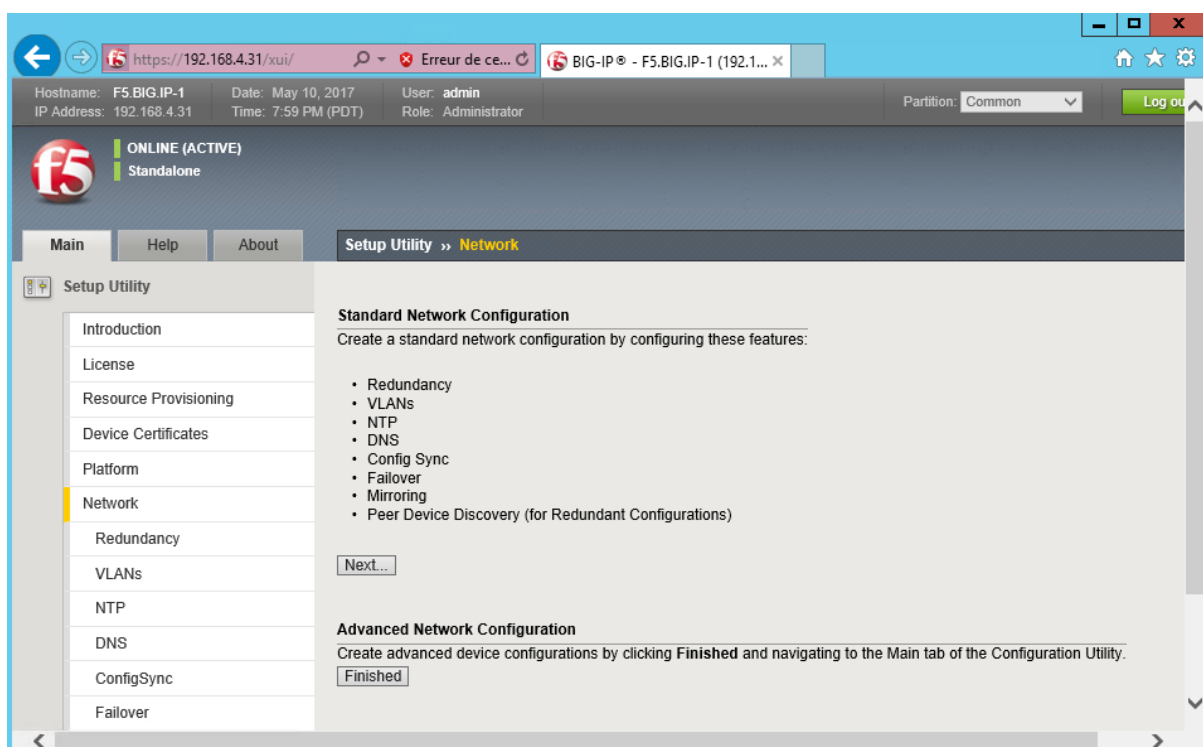

Internal VLAN (connected to web servers):

Configure the internal network and VLAN by making the following settings:

Self IP Address: 172.16.4.31

Netmask: 255.255.0.0

Port Lockdown: Allow Default

Floating IP Address: 172.16.4.33

Port Lockdown: Allow Default

Internal VLAN Configuration section

VLAN Name: internal

VLAN Tag ID: auto

VLAN Interfaces: Select VLAN interface 1.2 and add it Untagged to the Interfaces list.

Click **Next**.

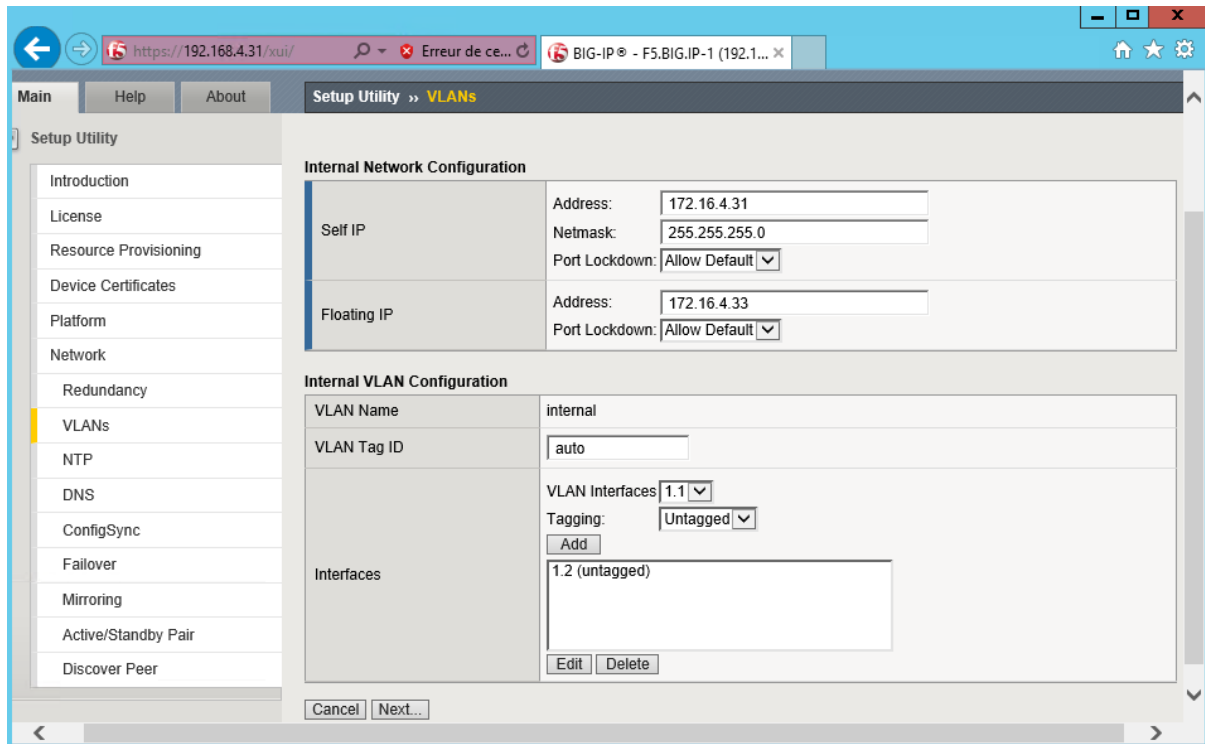

External VLAN (facing clients):

Configure the external network and VLAN by making the following settings:

External VLAN: Create VLAN external radio button selected

Self IP Address: 10.10.4.31

Netmask: 255.255.0.0

Port Lockdown: Allow 443

Default Gateway: Leave blank

Floating IP Address: 10.10.4.33

Port Lockdown: Allow Default

External VLAN Configuration section

VLAN Name: external

VLAN Tag ID: auto

VLAN Interfaces: Select VLAN interface 1.1 and add it Untagged to the Interfaces list.

Click **Next**.

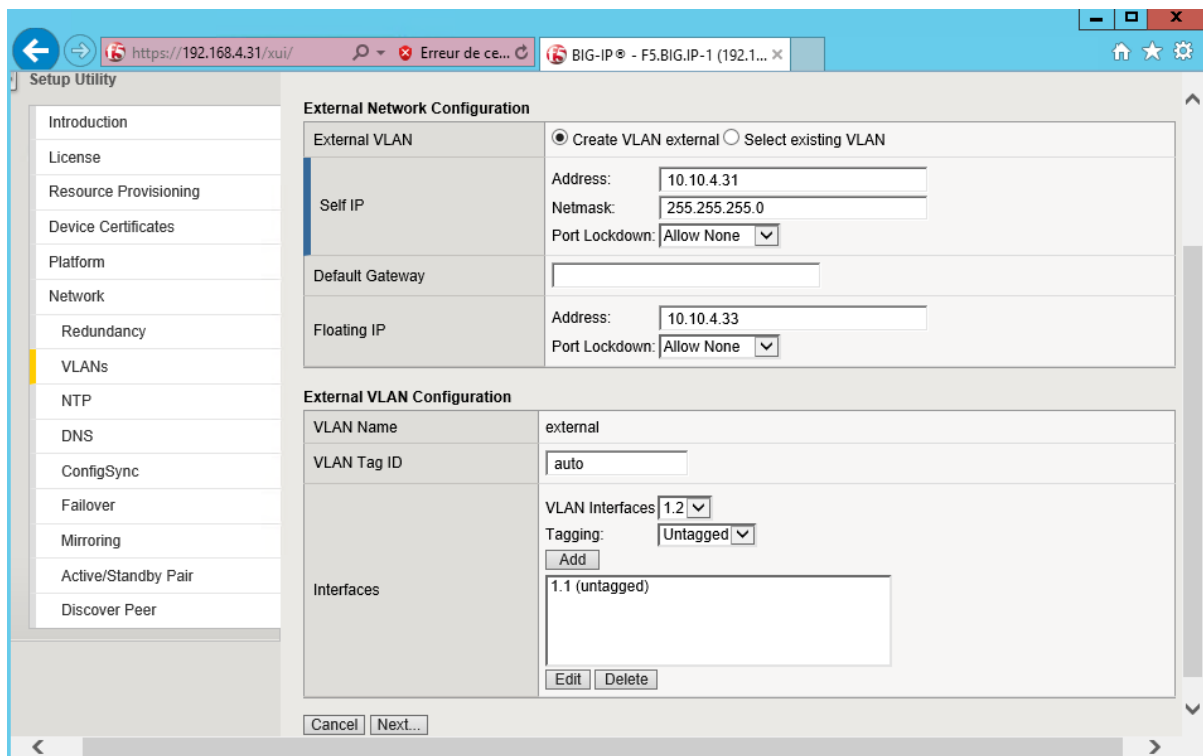

Configure the high availability network to use the existing VLAN, internal, by making the following settings:

High Availability VLAN: Click the Select existing VLAN radio button

Select VLAN: internal

Self IP Address: 172.16.4.31

Netmask: 255.255.0.0

High Availability VLAN Configuration section

VLAN Name: internal

VLAN Tag ID: auto

VLAN Interfaces: 1.2 (untagged)

Click **Next**.

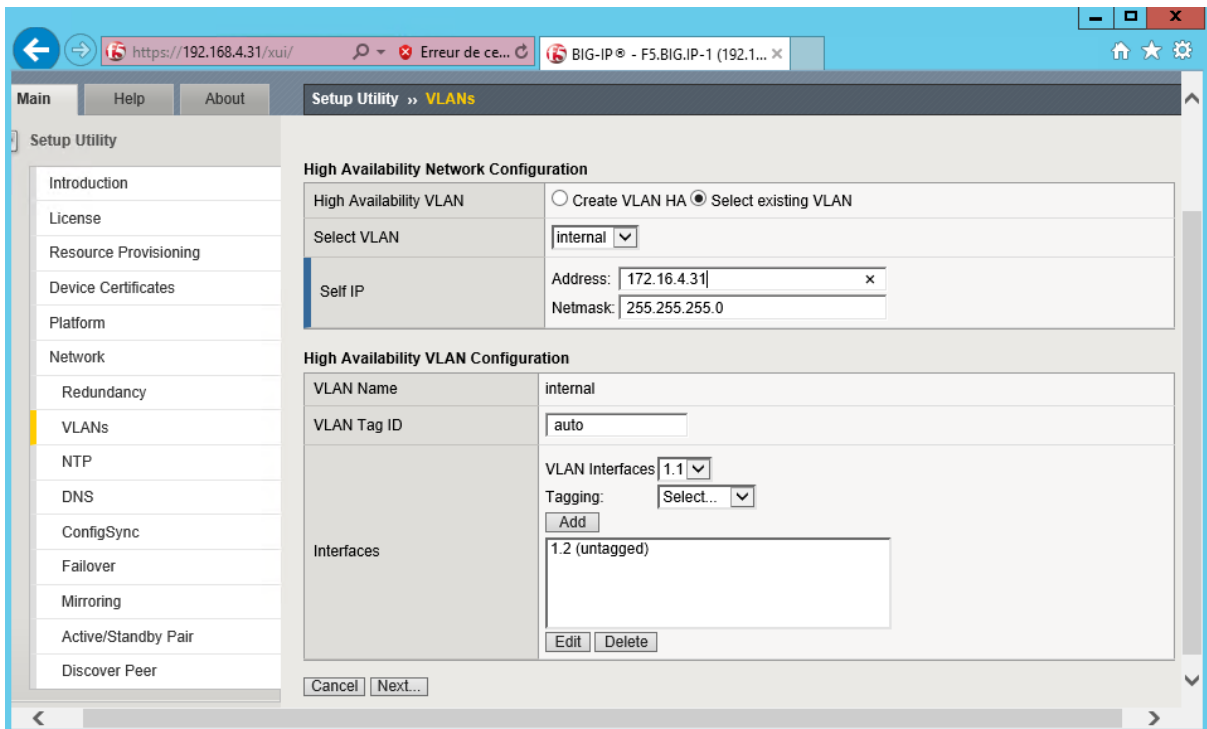

Configure Network Time Protocol

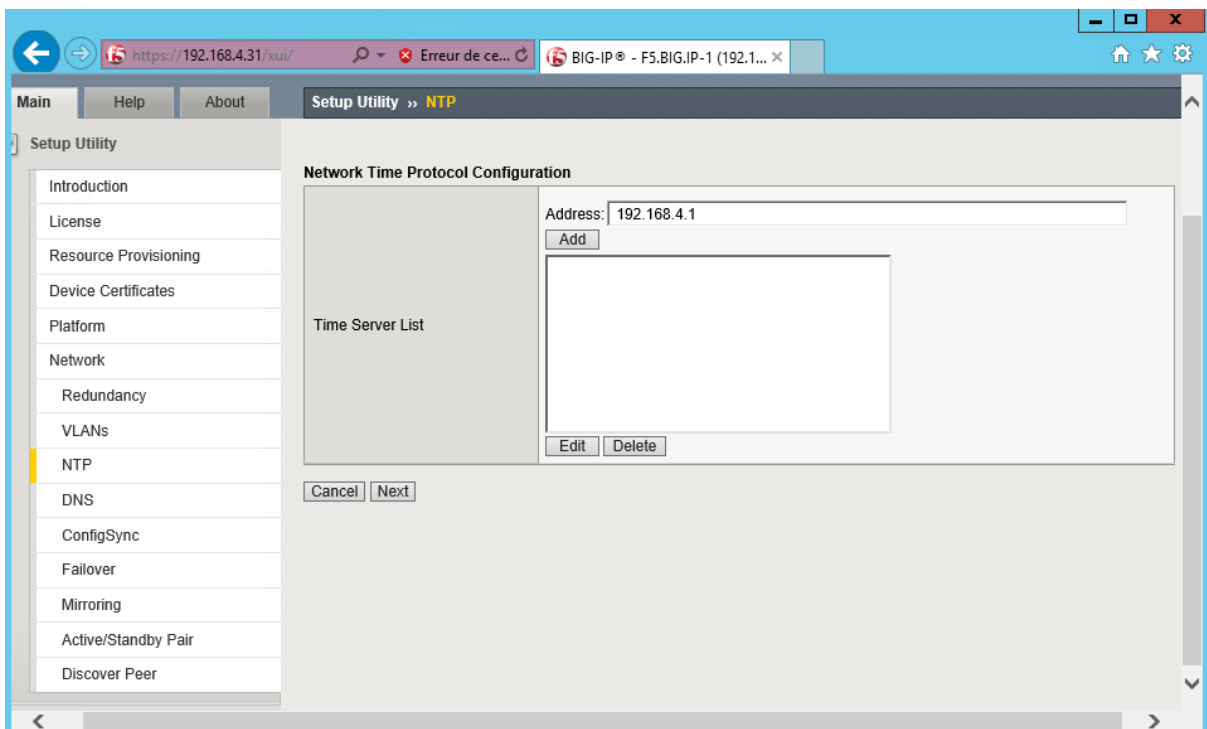

Configure Domain Name Server

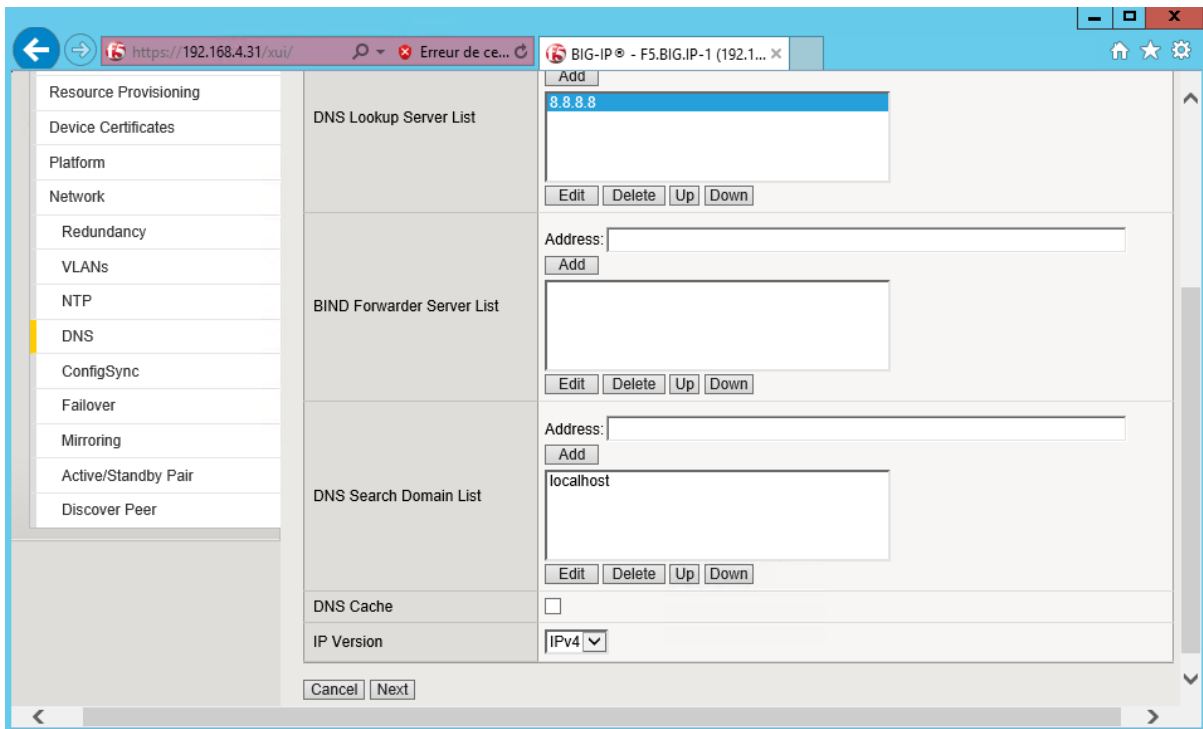

Configure ConfigSync

Configure ConfigSync on the non-floating self IP **172.16.4.31** for **internal** VLAN.

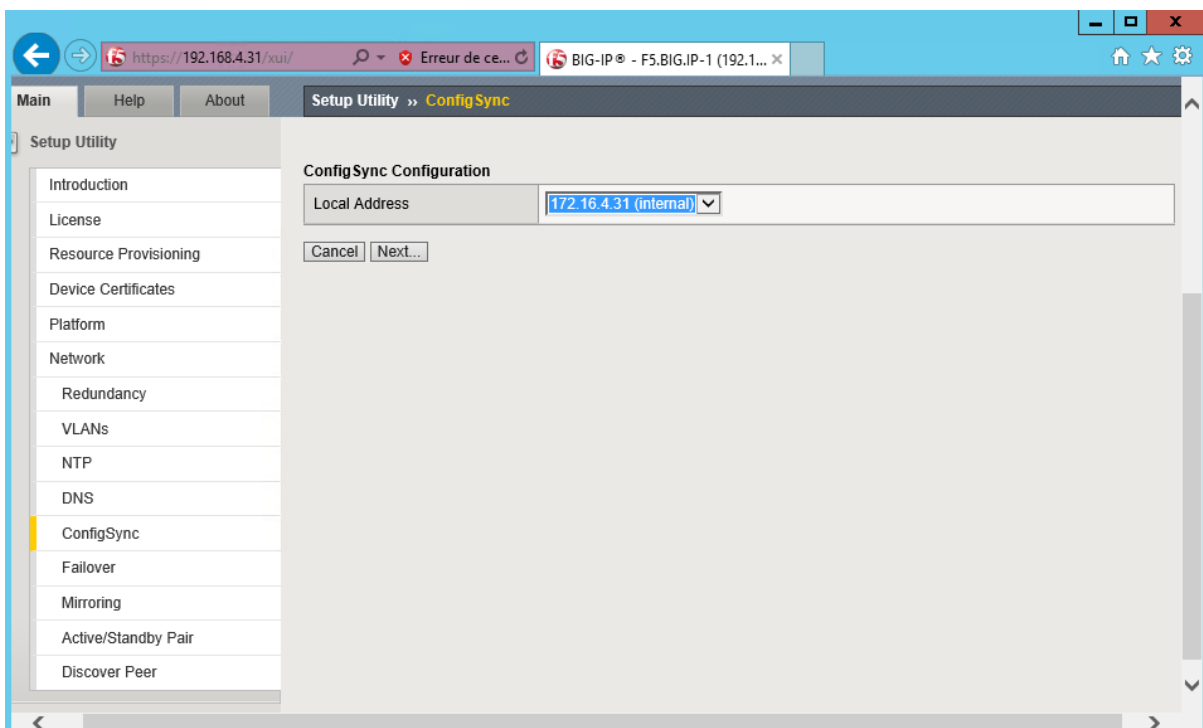

Use the default primary and secondary local mirror address settings for Mirroring Configuration.

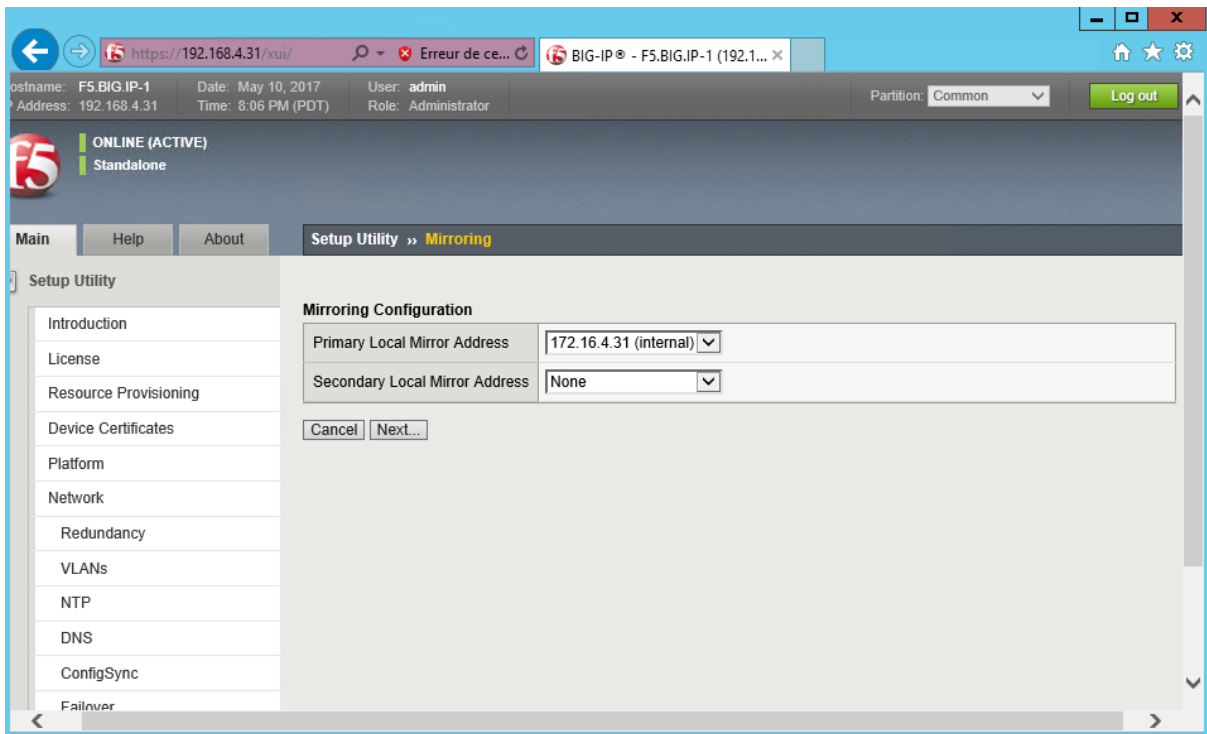

Click **Finished**.

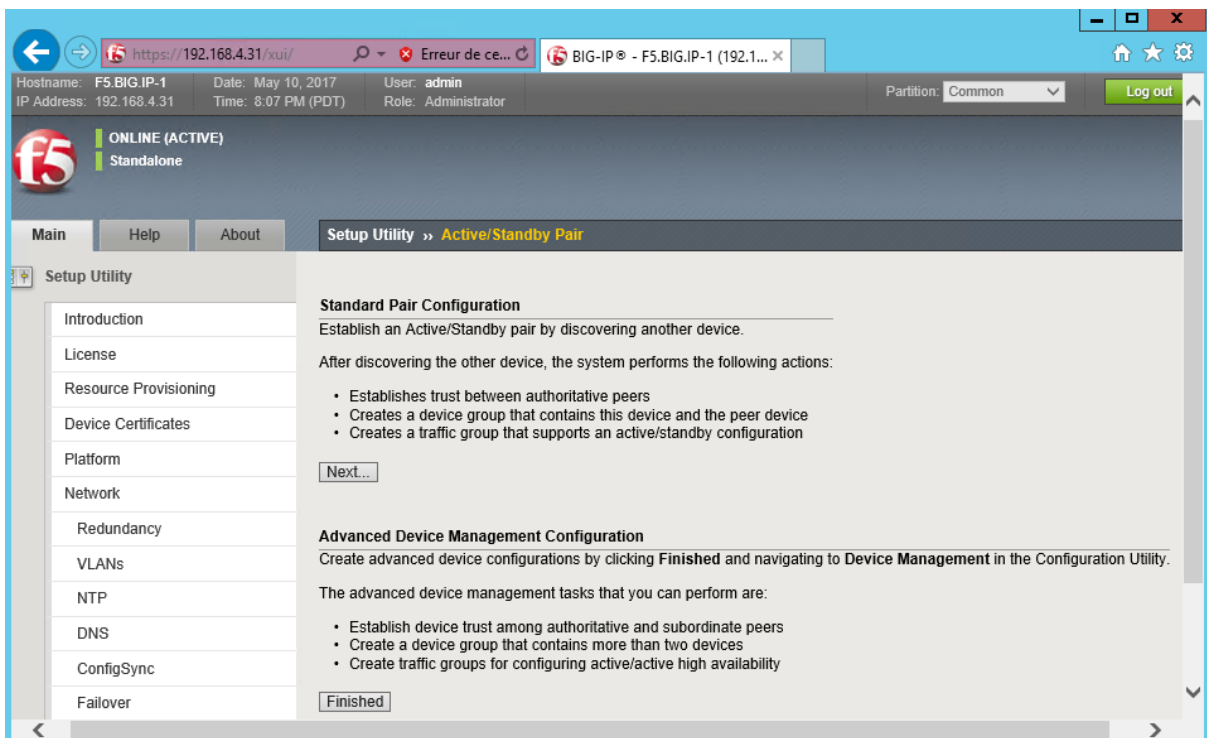

Lab 4: Configuration Backup

Create a UCS Archive of Your Configuration

Open a browser window to <https://192.168.4.31> and create a backup of your current configuration.

Configuration utility

System » Archives then click Create

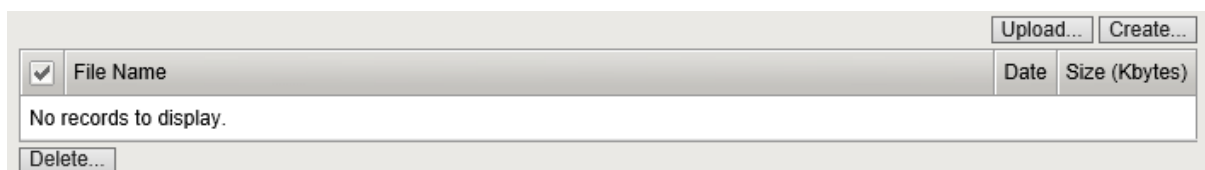
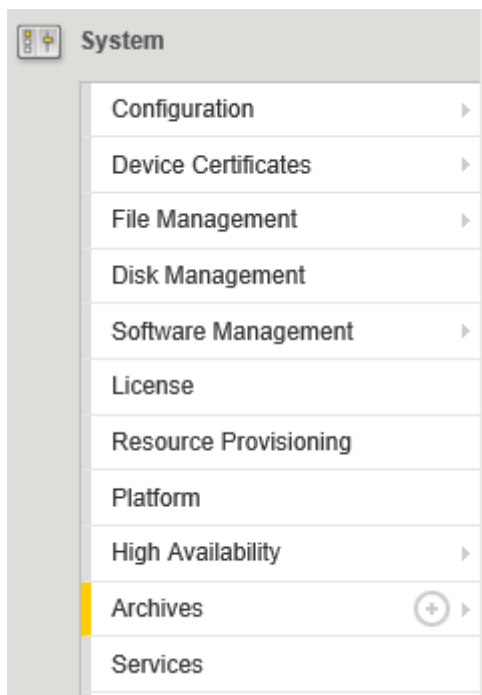

File Name: F5-LTM-BASE.ucs

Encryption: Disabled

Private Keys: Include

When complete, click **Finished**, then click **OK** when the archive is complete.

General Properties

File Name	F5-LTM-BASE.ucs
Encryption	Disabled
Private Keys	Include
Version	BIG-IP 12.1.2 Build 0.0.249

Cancel Finished

Operation Status

```

Saving active configuration...
/var/local/ucs/F5-LTM-BASE.ucs is saved.

tar: conf/ssl.crt/server.crt: time stamp 2017-04-23 04:54:07 is 23429.274680157 s in the future
tar: conf/ssl.crt: time stamp 2017-04-23 04:54:07 is 23429.245527071 s in the future
tar: conf/ssl.key/server.key: time stamp 2017-04-23 04:54:06 is 23428.245335924 s in the future
tar: conf/ssl.key: time stamp 2017-04-23 04:54:06 is 23428.24530194 s in the future
  
```

OK

Download your new UCS backup to your workstation.

System » Archives then click **F5-LTM-BASE.ucs**.

<input checked="" type="checkbox"/> File Name	Date	Size (Kbytes)
<input type="checkbox"/> F5-LTM-BASE.ucs	Sat Apr 22 22:23:55 CET 2017	3827

Upload... Create... Delete...

Click **Download: F5-LTM-BASE.ucs**, then save to download folder.

General Properties

File Name	F5-LTM-BASE.ucs
Version	BIG-IP 12.1.2 Build 0.0.249
Encrypted	No
Date	Sat Apr 22 22:23:55 CET 2017
Size	3827 Kilobytes
Archive File	Download: F5-LTM-BASE.ucs

Restore Delete

The F5-LTM-BASE.ucs download has completed. Open Open folder View downloads ×

Lab 5: Traffic Processing Pool and Virtual Server

Create a Pool

Create a Pool using the information in the following table.

Local Traffic » Pools » Pool List, then click **Create**

Configuration section:

Configuration: Basic

Name: HTTP-POOL

Resource section:

Load Balancing Method: Round Robin

Priority Group Activation: Disabled

Node Name: (Leave blank)

New Members:

Address:Port 172.16.4.10:80 Click **Add**

Address:Port 172.16.4.11:80 Click **Add**

Address:Port 172.16.4.12:80 Click **Add**

When complete, click **Finished**

Configuration: Basic

Name: HTTP-POOL

Description:

Health Monitors:

Active	Available
/Common http	/Common gateway_icmp http_head_f5 https https_443

Resources

Load Balancing Method: Round Robin

Priority Group Activation: Disabled

New Members:

New Node New FQDN Node

Node Name: (Optional)

Address: 172.16.4.12

Service Port: 80 HTTP

Add

```
R:1 P:0 C:0 172.16.4.10 172.16.4.10 :80
R:1 P:0 C:0 172.16.4.11 172.16.4.11 :80
R:1 P:0 C:0 172.16.4.12 172.16.4.12 :80
```

Edit Delete

Cancel Repeat Finished

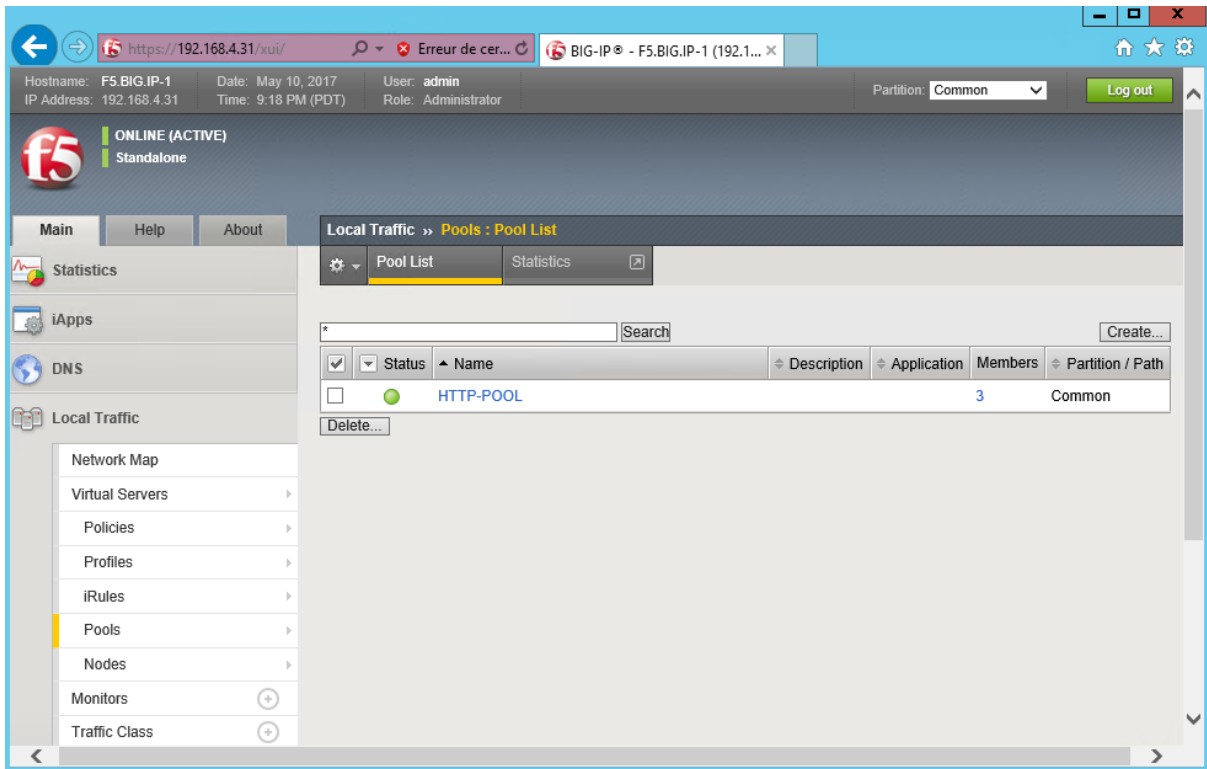

Create a Virtual Server

Create a Virtual Server that uses the pool created in the previous step.

Local Traffic » Virtual Servers » Virtual Server List, then click **Create**

General Properties section:

Name: VS-HTTP

Destination Type: Standard

Address: 10.10.4.100

Service Port: 80 (or type or select HTTP)

State: Enabled

General Properties	
Name	VS-HTTP
Description	
Type	Standard
Source Address	
Destination Address/Mask	10.10.4.100
Service Port	80 HTTP
Notify Status to Virtual Address	<input checked="" type="checkbox"/>
State	Enabled

Resources section:

Default Pool: HTTP-POOL

When complete, click **Finished**

Resources	
iRules	Enabled
	Available
Policies	Enabled
	Available
Default Pool	HTTP-POOL
Default Persistence Profile	None
Fallback Persistence Profile	None

Cancel Repeat Finished

Open a new browser session on the external client and point it to the virtual server at <http://10.10.4.100>.

The screenshot shows a web browser window with the address bar displaying `http://10.10.4.100/level/15/...` and a tab titled "Web-Server /level/15/...". The main content area features a heading "Web-Server" in a red-bordered box, followed by navigation links for "Home", "Exec", and "Configure". Below these is a "Command" input field. The "Output" section displays the following text:

```
Command base-URL was: /level/15/exec/-
Complete URL was:/level/15/exec/-/sh/run/int/fa0\0/0/CR
Command was: sh run int fa0/0

Building configuration...

Current configuration : 115 bytes
!
interface FastEthernet0/0
ip address 172.16.4.10 255.255.255.0
no ip route-cache
speed auto
duplex auto
end
```

The line `ip address 172.16.4.10 255.255.255.0` is highlighted with a red box.

Refresh the web page.

Web-Server

[Home](#) [Exec](#) [Configure](#)

Command

Output
Command base-URL was: /level/15/exec/-
Complete URL was: /level/15/exec/-/sh/run/int/fa0\0/CR
Command was: sh run int fa0/0

Building configuration...

Current configuration : 115 bytes
!
interface FastEthernet0/0
ip address 172.16.4.11 255.255.255.0
no ip route-cache
speed auto
duplex auto
end

Refresh the web page.



Create a Second Pool

Local Traffic » Pools: Pool List » New Pool

Configuration section:

Name: HTTPS-POOL

Resources section:

Load Balancing Method: Round Robin

Node Name: (Leave blank)

New Members:

Click **Node List** and use the resulting pull-down to select the nodes to add to the member list:

Address: 172.16.4.10 **Service Port:** 443 Click **Add**

Address: 172.16.4.11 **Service Port:** 443 Click **Add**

Address: 172.16.4.12 **Service Port:** 443 Click **Add**

When complete, click **Finished**

Name	HTTPS-POOL
Description	
Health Monitors	<div style="display: flex; justify-content: space-between;"> <div style="border: 1px solid gray; padding: 2px;">Active</div> <div style="border: 1px solid gray; padding: 2px;">Available</div> </div> <div style="display: flex; justify-content: space-between; margin-top: 5px;"> <div style="border: 1px solid gray; padding: 2px;">/Common https</div> <div style="text-align: center;"> << >> </div> <div style="border: 1px solid gray; padding: 2px;"> http http_head_f5 https_443 https_head_f5 inband </div> </div>
Resources	
Load Balancing Method	Round Robin
Priority Group Activation	Disabled
New Members	<input checked="" type="radio"/> New Node <input type="radio"/> New FQDN Node <input type="radio"/> Node List Node Name: <input type="text"/> (Optional) Address: <input type="text" value="172.16.4.12"/> x Service Port: <input type="text" value="443"/> <input type="text" value="HTTPS"/> <input type="text"/> <input type="button" value="Add"/> <div style="border: 1px solid gray; padding: 2px; margin-top: 5px;"> R:1 P:0 C:0 172.16.4.10 172.16.4.10 :443 R:1 P:0 C:0 172.16.4.11 172.16.4.11 :443 R:1 P:0 C:0 172.16.4.12 172.16.4.12 :443 </div> <input type="button" value="Edit"/> <input type="button" value="Delete"/>
<input type="button" value="Cancel"/> <input type="button" value="Repeat"/> <input type="button" value="Finished"/>	

Local Traffic » Pools : Pool List

Pool List Statistics

*

<input checked="" type="checkbox"/>	Status	Name	Description	Application	Members	Partition / Path
<input type="checkbox"/>	●	HTTP-POOL			3	Common
<input type="checkbox"/>	●	HTTPS-POOL			3	Common

Create a Virtual Server that uses the pool **HTTPS-POOL** created in the previous step.

Local Traffic » Virtual Servers » Virtual Server List, then click **Create**

General Properties section:

Name: VS-HTTPS

Destination Type: Standard

Address: 10.10.4.101

Service Port: 443 (or type or select HTTP)

State: Enabled

Local Traffic » Virtual Servers : Virtual Server List » **New Virtual Server...**

General Properties

Name	VS-HTTPS
Description	
Type	Standard
Source Address	
Destination Address/Mask	10.10.4.101
Service Port	443 HTTPS
Notify Status to Virtual Address	<input checked="" type="checkbox"/>
State	Enabled

Resources section:

Default Pool: HTTPS-POOL

When complete, click **Finished**

Resources

iRules	<table border="1"> <thead> <tr> <th>Enabled</th> <th>Available</th> </tr> </thead> <tbody> <tr> <td></td> <td> _sys_auth_ssl_cc_ldap _sys_auth_ssl_cridp _sys_auth_ssl_ocsp _sys_auth_tacacs _sys_https_redirect </td> </tr> </tbody> </table>	Enabled	Available		_sys_auth_ssl_cc_ldap _sys_auth_ssl_cridp _sys_auth_ssl_ocsp _sys_auth_tacacs _sys_https_redirect
Enabled	Available				
	_sys_auth_ssl_cc_ldap _sys_auth_ssl_cridp _sys_auth_ssl_ocsp _sys_auth_tacacs _sys_https_redirect				
Policies	<table border="1"> <thead> <tr> <th>Enabled</th> <th>Available</th> </tr> </thead> <tbody> <tr> <td></td> <td></td> </tr> </tbody> </table>	Enabled	Available		
Enabled	Available				
Default Pool	HTTPS-POOL				
Default Persistence Profile	None				
Fallback Persistence Profile	None				

Cancel Repeat Finished

Open a new browser session on the external client and enter the address of the virtual server at <https://10.10.4.100>.

Web-Server

[Home](#) [Exec](#) [Configure](#)

Command

Output
Command base-URL was: /level/15/exec/-
Complete URL was: /level/15/exec/-/sh/run/int/fa0\0/CR
Command was: sh run int fa0/0

Building configuration...

Current configuration : 115 bytes
!
interface FastEthernet0/0
ip address 172.16.4.10 255.255.255.0
no ip route-cache
speed auto
duplex auto
end

Refresh the web page

The screenshot shows a web browser window with the address bar containing `https://10.10.4.101/level/15/...`. The page title is **Web-Server**. There are three navigation tabs: [Home](#), [Exec](#), and [Configure](#). Below the tabs is a text input field labeled "Command". The "Output" section displays the following text:

```
Command base-URL was: /level/15/exec/-  
Complete URL was: /level/15/exec/-/sh/run/int/fa0\0/CR  
Command was: sh run int fa0/0  
  
Building configuration...  
  
Current configuration : 115 bytes  
!  
interface FastEthernet0/0  
ip address 172.16.4.11 255.255.255.0  
no ip route-cache  
speed auto
```

Refresh the web page

https://10.10.4.101/... Waiting for 10.10.4.101

Web-Server

[Home](#) [Exec](#) [Configure](#)

Command

Output

```
Command base-URL was: /level/15/exec/-  
Complete URL was: /level/15/exec/-/sh/run/int/fa0\0/CR  
Command was: sh run int fa0/0
```

```
Building configuration...  
  
Current configuration : 115 bytes  
!  
interface FastEthernet0/0  
ip address 172.16.4.12 255.255.255.0  
no ip route-cache  
speed auto
```

Lab 6: Load Balancing

Configure Ratio (member) Load Balancing.

In the Navigation pane, expand the Local Traffic section.

Click **Pools**.

Click **HTTP-POOL**.

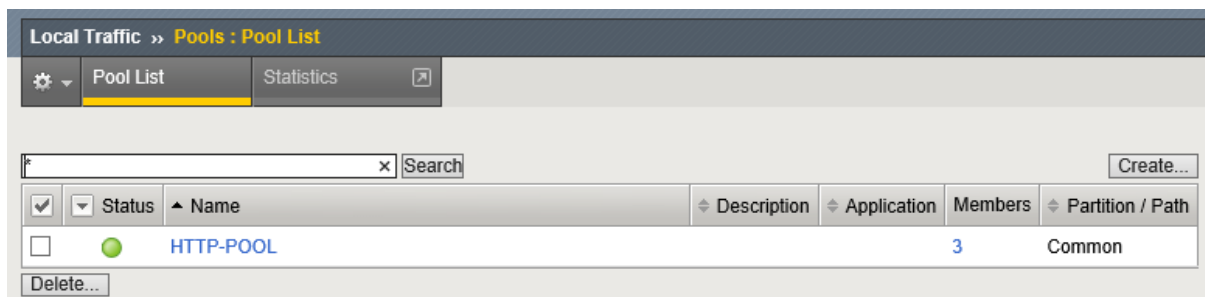

Click the **Members** tab.

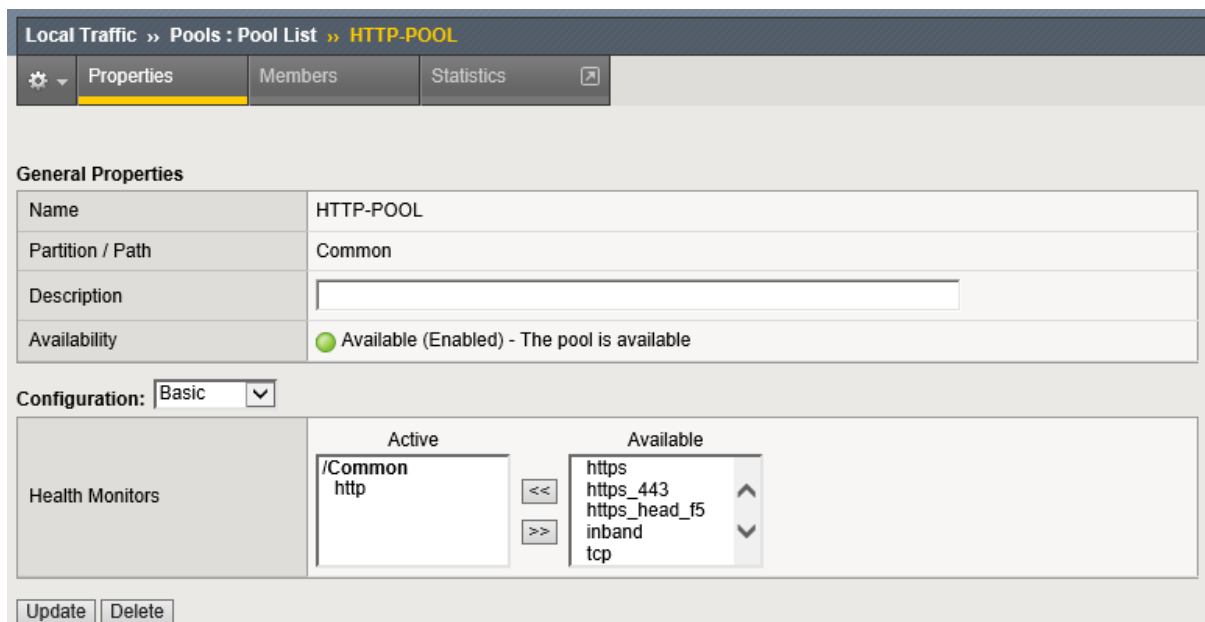

In the **Load Balancing** section, change Load Balancing Method to **Ratio (member)** and then click **Update**.

Local Traffic » Pools : Pool List » HTTP-POOL

Properties Members Statistics

Load Balancing

Load Balancing Method: Round Robin

Priority Group Activation: Disabled

Update

Current Members Add...

<input checked="" type="checkbox"/>	Status	Member	Address	Service Port	FQDN	Ephemeral	Ratio	Priority Group	Connection Limit	Partition / Path
<input type="checkbox"/>	●	172.16.4.10:80	172.16.4.10	80		No	1	0 (Active)	0	Common
<input type="checkbox"/>	●	172.16.4.11:80	172.16.4.11	80		No	1	0 (Active)	0	Common
<input type="checkbox"/>	●	172.16.4.12:80	172.16.4.12	80		No	1	0 (Active)	0	Common

Enable Disable Force Offline Remove

Local Traffic » Pools : Pool List » HTTP-POOL

Properties Members Statistics

Load Balancing

Load Balancing Method: Ratio (member)

Ignore Persisted Weight:

Priority Group Activation: Disabled

Update

Current Members Add...

<input checked="" type="checkbox"/>	Status	Member	Address	Service Port	FQDN	Ephemeral	Ratio	Priority Group	Connection Limit	Partition / Path
<input type="checkbox"/>	●	172.16.4.10:80	172.16.4.10	80		No	1	0 (Active)	0	Common
<input type="checkbox"/>	●	172.16.4.11:80	172.16.4.11	80		No	2	0 (Active)	0	Common
<input type="checkbox"/>	●	172.16.4.12:80	172.16.4.12	80		No	3	0 (Active)	0	Common

Enable Disable Force Offline Remove

Local Traffic » Pools : Pool List » HTTP-POOL

Properties Members Statistics

Load Balancing

Load Balancing Method: Ratio (member)

Ignore Persisted Weight:

Priority Group Activation: Disabled

Update

Current Members Add...

<input checked="" type="checkbox"/>	Status	Member	Address	Service Port	FQDN	Ephemeral	Ratio	Priority Group	Connection Limit	Partition / Path
<input type="checkbox"/>	●	172.16.4.10:80	172.16.4.10	80		No	1	0 (Active)	0	Common
<input type="checkbox"/>	●	172.16.4.11:80	172.16.4.11	80		No	2	0 (Active)	0	Common
<input type="checkbox"/>	●	172.16.4.12:80	172.16.4.12	80		No	3	0 (Active)	0	Common

Enable Disable Force Offline Remove

In the Current **Members** section, click each member, set **Ratio** to the value in the table and then click **Update**. Click the Members tab to return to the Current Members list.

Member Ratio

172.16.4.10:80 1 (default)

172.16.4.11:80 2

172.16.4.12:80 3

Address	172.16.4.11
Service Port	80
Partition / Path	Common
Description	<input type="text"/>
Parent Node	172.16.4.11
Availability	Available (Enabled) - Pool member is available 2017-05-11 22:59:07
Health Monitors	http
Monitor Logging	<input type="checkbox"/> Enable
Current Connections	0
State	<input checked="" type="radio"/> Enabled (All traffic allowed) <input type="radio"/> Disabled (Only persistent or active connections allowed) <input type="radio"/> Forced Offline (Only active connections allowed)

Configuration: Basic

Ratio	<input type="text" value="2"/> <input type="button" value="x"/>
Priority Group	<input type="text" value="0"/>
Connection Limit	<input type="text" value="0"/>
Connection Rate Limit	<input type="text" value="0"/>

Address	172.16.4.12
Service Port	80
Partition / Path	Common
Description	<input type="text"/>
Parent Node	172.16.4.12
Availability	Available (Enabled) - Pool member is available 2017-05-11 22:56:21
Health Monitors	http
Monitor Logging	<input type="checkbox"/> Enable
Current Connections	0
State	<input checked="" type="radio"/> Enabled (All traffic allowed) <input type="radio"/> Disabled (Only persistent or active connections allowed) <input type="radio"/> Forced Offline (Only active connections allowed)

Configuration: Basic

Ratio	<input type="text" value="3"/> <input type="button" value="x"/>
Priority Group	<input type="text" value="0"/>
Connection Limit	<input type="text" value="0"/>
Connection Rate Limit	<input type="text" value="0"/>

Open a new browser session on the external client and connect to <http://10.10.4.100>.

Refresh the browser 5-10 times.

In the Configuration Utility, view the **pool statistics**. Traffic should be distributed to the members with a **1:2:3 ratio**.

Statistics » Module Statistics : Local Traffic » Pools

Traffic Summary | DNS | **Local Traffic** | Network | Memory

Display Options

Statistics Type: Pools
Data Format: Normalized
Auto Refresh: Disabled Refresh

/Common/HTTP-POOL		Search	Reset Search	Bits		Packets		Connections			Requests	
✓	▼ Status	▲ Pool	◆ Pool Member	◆ Partition / Path	◆ In	◆ Out	◆ In	◆ Out	◆ Current	◆ Maximum	◆ Total	◆ Total
<input type="checkbox"/>	●	HTTP-POOL		Common	43.8K	218.3K	66	67	0	6	9	0
<input type="checkbox"/>	●		172.16.4.10:80	Common	9.0K	47.4K	14	14	0	2	2	0
<input type="checkbox"/>	●		172.16.4.11:80	Common	13.5K	72.5K	21	21	0	2	3	0
<input type="checkbox"/>	●		172.16.4.12:80	Common	21.2K	98.2K	31	32	0	2	4	0

Reset

Priority Group Activation Lab

Configure Priority Group Activation

Reset the statistics for **HTTP-POOL**.

From the Navigation pane, expand the **Local Traffic** section and select **Pools**.

Select **HTTP-POOL**.

Select the **Members** tab.

In the Load Balancing section, change the **Priority Group Activation** setting to **Less than...**, the number of Available Members to **2**, and click **Update**.

Local Traffic » Pools : Pool List » HTTP-POOL

Properties | **Members** | Statistics

Load Balancing

Load Balancing Method: Ratio (member)
Ignore Persisted Weight:
Priority Group Activation: **Less than...** 0 Available Member(s)

Update

Current Members Add...

✓	▼ Status	◆ Member	▲ Address	◆ Service Port	◆ FQDN	◆ Ephemeral	◆ Ratio	◆ Priority Group	◆ Connection Limit	◆ Partition / Path
<input type="checkbox"/>	●	172.16.4.10:80	172.16.4.10	80		No	1	0 (Active)	0	Common
<input type="checkbox"/>	●	172.16.4.11:80	172.16.4.11	80		No	2	0 (Active)	0	Common
<input type="checkbox"/>	●	172.16.4.12:80	172.16.4.12	80		No	3	0 (Active)	0	Common

Enable | Disable | Force Offline | Remove

Local Traffic » Pools : Pool List » HTTP-POOL

Properties Members Statistics

Load Balancing

Load Balancing Method: Ratio (member)

Ignore Persisted Weight:

Priority Group Activation: Less than... 2 Available Member(s)

Update

Current Members Add...

<input type="checkbox"/>	Status	Member	Address	Service Port	FQDN	Ephemeral	Ratio	Priority Group	Connection Limit	Partition / Path
<input type="checkbox"/>	●	172.16.4.10:80	172.16.4.10	80		No	1	0 (Active)	0	Common
<input type="checkbox"/>	●	172.16.4.11:80	172.16.4.11	80		No	2	0 (Active)	0	Common
<input type="checkbox"/>	●	172.16.4.12:80	172.16.4.12	80		No	3	0 (Active)	0	Common

Enable Disable Force Offline Remove

Within the **Configuration** section of each member, set the **Priority** values as follows:

Member Ratio Priority Group

172.16.4.10:80 1 0

172.16.4.11:80 2 4

172.16.4.12:80 3 4

Address	172.16.4.11
Service Port	80
Partition / Path	Common
Description	
Parent Node	■ 172.16.4.11
Availability	● Available (Enabled) - Pool member is available 2017-05-11 22:59:07
Health Monitors	● http
Monitor Logging	<input type="checkbox"/> Enable
Current Connections	0
State	<input checked="" type="radio"/> Enabled (All traffic allowed) <input type="radio"/> Disabled (Only persistent or active connections allowed) <input type="radio"/> Forced Offline (Only active connections allowed)

Configuration: Basic

Ratio	2
Priority Group	4
Connection Limit	0
Connection Rate Limit	0

Update Delete

Address	172.16.4.12
Service Port	80
Partition / Path	Common
Description	<input type="text"/>
Parent Node	<input checked="" type="checkbox"/> 172.16.4.12
Availability	<input checked="" type="radio"/> Available (Enabled) - Pool member is available 2017-05-11 22:56:21
Health Monitors	<input checked="" type="radio"/> http
Monitor Logging	<input type="checkbox"/> Enable
Current Connections	0
State	<input checked="" type="radio"/> Enabled (All traffic allowed) <input type="radio"/> Disabled (Only persistent or active connections allowed) <input type="radio"/> Forced Offline (Only active connections allowed)

Configuration:

Ratio	<input type="text" value="3"/>
Priority Group	<input type="text" value="4"/> x
Connection Limit	<input type="text" value="0"/>
Connection Rate Limit	<input type="text" value="0"/>

Local Traffic » Pools : Pool List » HTTP-POOL

Load Balancing

Load Balancing Method	<input type="text" value="Ratio (member)"/>
Ignore Persisted Weight	<input type="checkbox"/>
Priority Group Activation	<input type="text" value="Less than..."/> <input type="text" value="2"/> Available Member(s)

Current Members

<input checked="" type="checkbox"/>	<input type="checkbox"/> Status	<input type="checkbox"/> Member	<input type="checkbox"/> Address	<input type="checkbox"/> Service Port	<input type="checkbox"/> FQDN	<input type="checkbox"/> Ephemeral	<input type="checkbox"/> Ratio	<input type="checkbox"/> Priority Group	<input type="checkbox"/> Connection Limit	<input type="checkbox"/> Partition / Path
<input type="checkbox"/>	<input checked="" type="radio"/>	172.16.4.10:80	172.16.4.10	80		No	1	0 (Active)	0	Common
<input type="checkbox"/>	<input checked="" type="radio"/>	172.16.4.11:80	172.16.4.11	80		No	2	4 (Active)	0	Common
<input type="checkbox"/>	<input checked="" type="radio"/>	172.16.4.12:80	172.16.4.12	80		No	3	4 (Active)	0	Common

Open a new browser session on the external client and connect to <http://10.10.4.100>.
 Refresh the screen 5-10 times.
 View the **pool statistics**.

With Priority Group Activation set to less than 2 members and all pool members enabled, **172.16.4.11:80** should receive no traffic. Traffic is distributed to members **172.16.4.11** and **172.16.4.12** in a **2:3 ratio**.

Statistics » Module Statistics : Local Traffic » Pools

Traffic Summary DNS Local Traffic Network Memory

Display Options

Statistics Type: Pools

Data Format: Normalized

Auto Refresh: Disabled Refresh

/Common/HTTP-POOL		Search	Reset Search	Bits		Packets		Connections			Requests	
<input type="checkbox"/>	Status	Pool	Pool Member	Partition / Path	In	Out	In	Out	Current	Maximum	Total	Total
<input type="checkbox"/>	●	HTTP-POOL		Common	31.3K	154.2K	48	49	0	4	7	0
<input type="checkbox"/>	●		172.16.4.10:80	Common	0	0	0	0	0	0	0	0
<input type="checkbox"/>	●		172.16.4.11:80	Common	12.9K	58.1K	19	19	0	2	3	0
<input type="checkbox"/>	●		172.16.4.12:80	Common	18.4K	96.0K	29	30	0	2	4	0

Reset

Reset the statistics for **HTTP-POOL**.
 Disable pool member **172.16.4.11:80** in **HTTP-POOL**.

Local Traffic » Pools : Pool List » HTTP-POOL

Properties Members Statistics

Load Balancing

Load Balancing Method: Ratio (member)

Ignore Persisted Weight:

Priority Group Activation: Less than... 2 Available Member(s)

Update

Current Members Add...

<input type="checkbox"/>	Status	Member	Address	Service Port	FQDN	Ephemeral	Ratio	Priority Group	Connection Limit	Partition / Path
<input type="checkbox"/>	●	172.16.4.10:80	172.16.4.10	80		No	1	0 (Active)	0	Common
<input checked="" type="checkbox"/>	●	172.16.4.11:80	172.16.4.11	80		No	2	4 (Active)	0	Common
<input type="checkbox"/>	●	172.16.4.12:80	172.16.4.12	80		No	3	4 (Active)	0	Common

Enable Disable Force Offline Remove

Current Members Add...

<input type="checkbox"/>	Status	Member	Address	Service Port	FQDN	Ephemeral	Ratio	Priority Group	Connection Limit	Partition / Path
<input type="checkbox"/>	●	172.16.4.10:80	172.16.4.10	80		No	1	0 (Active)	0	Common
<input type="checkbox"/>	●	172.16.4.11:80	172.16.4.11	80		No	2	4 (Active)	0	Common
<input type="checkbox"/>	●	172.16.4.12:80	172.16.4.12	80		No	3	4 (Active)	0	Common

Enable Disable Force Offline Remove

In the browser session connect to <http://10.10.4.100>, refresh the screen 5-10 times by pressing.
 Refresh and view the pool statistics.

With Priority Group Activation set to less than 2 members and pool member **172.16.4.11:80** disabled, **172.16.4.11:80** is not eligible to receive traffic. The next lower priority group (**0**) is activated as the number of available members in the pool has now fallen below the minimum 2. Traffic is distributed to members **172.16.4.10** and **172.16.4.12** in a **1:3 ratio**

Statistics » Module Statistics : Local Traffic » Pools														
Traffic Summary		DNS		Local Traffic		Network		Memory						
Display Options														
Statistics Type		Pools												
Data Format		Normalized												
Auto Refresh		Disabled Refresh												
/Common/HTTP-POOL				Search		Reset Search		Bits		Packets		Connections		Requests
<input checked="" type="checkbox"/>	Status	Pool	Pool Member	Partition / Path	In	Out	In	Out	Current	Maximum	Total	Total		
<input type="checkbox"/>	●	HTTP-POOL		Common	34.7K	133.1K	47	46	0	4	8	0		
<input type="checkbox"/>	●		172.16.4.10:80	Common	9.2K	37.2K	12	12	0	2	2	0		
<input type="checkbox"/>	●		172.16.4.11:80	Common	0	0	0	0	0	0	0	0		
<input type="checkbox"/>	●		172.16.4.12:80	Common	25.4K	95.9K	35	34	0	2	6	0		
Reset														

Enable pool member **172.16.4.11:80** in **HTTP-POOL**.

Lab 7: Monitors

Create a Custom ICMP Monitor
Create a new ICMP monitor called **MY-ICMP**.

Local Traffic » Monitors » Create

General Properties section:

Name: MY-ICMP

Type: ICMP

Configuration section:

Interval: 10 seconds

Timeout: 31 seconds

Transparent: No

When complete, click **Finished**

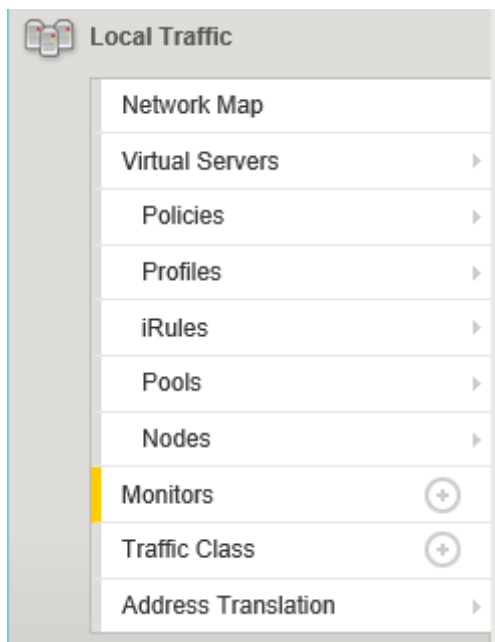

Local Traffic » Monitors

Monitor List

Search

Create...

Name	Application	Type	Partition / Path
gateway_icmp		Gateway ICMP	Common
http		HTTP	Common
http_head_f5		HTTP	Common
https		HTTPS	Common
https_443		HTTPS	Common
https_head_f5		HTTPS	Common
icmp		ICMP	Common
inband		Inband	Common
real_server		Real Server	Common
snmp_dca		SNMP DCA	Common

Delete...

Page 1 of 2

General Properties

Name: MY-ICMP

Description:

Type: ICMP

Parent Monitor: icmp

Configuration: Basic

Interval: 10 seconds

Timeout: 31 seconds

Transparent: Yes No

Alias Address: * All Addresses

Adaptive: Enabled

Cancel Repeat Finished

Local Traffic » Monitors

Monitor List

Search

Create...

Name	Application	Type	Partition / Path
MY-ICMP		ICMP	Common
gateway_icmp		Gateway ICMP	Common
http		HTTP	Common
http_head_f5		HTTP	Common
https		HTTPS	Common
https_443		HTTPS	Common
https_head_f5		HTTPS	Common
icmp		ICMP	Common
inband		Inband	Common
real_server		Real Server	Common

Delete...

Page 1 of 2

Assign the custom monitor to selected node

Add **MY-ICMP** as the default monitor for node **172.16.4.10**.

Local Traffic » Nodes: Node List » 172.16.4.10

Configuration section:

Health Monitors: Node Specific

Select Monitors: Select MY-ICMP

Press << button

When complete, click **Update**

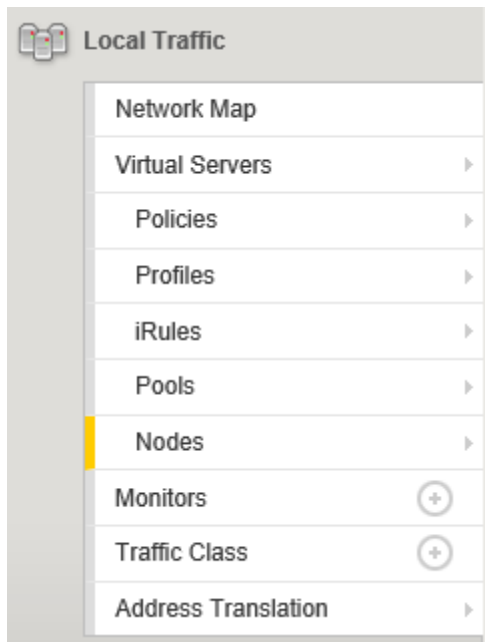

Local Traffic » Nodes : Node List

Node List | Default Monitor | Statistics

* Search Create...

<input checked="" type="checkbox"/>	Status	Name	Description	Application	Address	FQDN	Ephemeral	Partition / Path
<input type="checkbox"/>	<input checked="" type="checkbox"/>	172.16.4.10			172.16.4.10		No	Common
<input type="checkbox"/>	<input checked="" type="checkbox"/>	172.16.4.11			172.16.4.11		No	Common
<input type="checkbox"/>	<input checked="" type="checkbox"/>	172.16.4.12			172.16.4.12		No	Common

Enable | Disable | Force Offline | Delete...

General Properties

Name	172.16.4.10
Address	172.16.4.10
Partition / Path	Common
Description	
Availability	<input checked="" type="checkbox"/> Unknown (Enabled) - Node address does not have service checking enabled 2017-05-11 22:56:19
Monitor Logging	<input type="checkbox"/> Enable
Current Connections	0
State	<input checked="" type="radio"/> Enabled (All traffic allowed) <input type="radio"/> Disabled (Only persistent or active connections allowed) <input type="radio"/> Forced Offline (Only active connections allowed)

Configuration

Health Monitors	Node Specific
Select Monitors	<div style="display: flex; justify-content: space-between;"> <div style="border: 1px solid gray; padding: 2px;"> <p>Active</p> <p>/Common</p> <p>MY-ICMP</p> </div> <div style="border: 1px solid gray; padding: 2px;"> <p>Available</p> <p>https_443</p> <p>icmp</p> <p>real_server</p> <p>snmp_dca</p> <p>tcp_echo</p> </div> </div>
Availability Requirement	All Health Monitor(s)
Ratio	1
Connection Limit	0
Connection Rate Limit	0

Update Delete

Check node status indicators.

General Properties

Name	172.16.4.10
Address	172.16.4.10
Partition / Path	Common
Description	
Availability	● Available (Enabled) - Node address is available 2017-05-11 23:30:53
Health Monitors	● MY-ICMP
Monitor Logging	<input type="checkbox"/> Enable
Current Connections	0
State	<input checked="" type="radio"/> Enabled (All traffic allowed) <input type="radio"/> Disabled (Only persistent or active connections allowed) <input type="radio"/> Forced Offline (Only active connections allowed)

Local Traffic » Nodes : Node List

Node List Default Monitor Statistics

* Search Create...

✓	Status	Name	Description	Application	Address	FQDN	Ephemeral	Partition / Path
<input type="checkbox"/>	●	172.16.4.10			172.16.4.10		No	Common
<input type="checkbox"/>	●	172.16.4.11			172.16.4.11		No	Common
<input type="checkbox"/>	●	172.16.4.12			172.16.4.12		No	Common

Enable Disable Force Offline Delete...

Disassociate all monitors from selected node
 Remove the monitor from node **172.16.4.11**. Leave monitor **MY-ICMP** on **172.16.4.10**.

Local Traffic » Nodes: Node List » 172.16.4.11

Configuration section:
Health Monitors: None
 When complete, click **Update**

General Properties	
Name	172.16.4.11
Address	172.16.4.11
Partition / Path	Common
Description	<input type="text"/>
Availability	<input checked="" type="checkbox"/> Unknown (Enabled) - Node address does not have service checking enabled 2017-05-11 22:56:19
Monitor Logging	<input type="checkbox"/> Enable
Current Connections	0
State	<input checked="" type="radio"/> Enabled (All traffic allowed) <input type="radio"/> Disabled (Only persistent or active connections allowed) <input type="radio"/> Forced Offline (Only active connections allowed)

Configuration	
Health Monitors	<div style="border: 1px solid black; padding: 2px;"> Node Default Node Specific None </div>
Ratio	<input type="text" value="1"/>
Connection Limit	<input type="text" value="0"/>
Connection Rate Limit	<input type="text" value="0"/>

Configuration	
Health Monitors	None ▼
Ratio	<input type="text" value="1"/>
Connection Limit	<input type="text" value="0"/>
Connection Rate Limit	<input type="text" value="0"/>

Check the nodes' statuses.

Node 172.16.4.10 has a specific assignment, MY-ICMP.

Node 172.16.4.11 has no monitor assigned.

Create a New HTTP Monitor

Create a customized monitor based on the HTTP Monitor.

Local Traffic » Monitors » New Monitor

General Properties:

Name: MY-HTTP

Type: HTTP

Parent Monitor: http

Configuration section:

Send String: GET /index.html\r\n

Receive String: Server

When complete, click **Finished**

General Properties

Name	MY-HTTP
Description	
Type	HTTP
Parent Monitor	http

Configuration: Basic

Interval	5 seconds
Timeout	16 seconds
Send String	GET /\r\n
Receive String	Server
Receive String	Server
Receive Disable String	
User Name	
Password	
Reverse	<input type="radio"/> Yes <input checked="" type="radio"/> No
Transparent	<input type="radio"/> Yes <input checked="" type="radio"/> No
Alias Address	* All Addresses
Alias Service Port	* All Ports
Adaptive	<input type="checkbox"/> Enabled

Cancel Repeat Finished

Local Traffic » Monitors

Monitor List

* Search Create...

<input checked="" type="checkbox"/>	Name	Application	Type	Partition / Path
<input type="checkbox"/>	MY-HTTP		HTTP	Common
<input type="checkbox"/>	MY-ICMP		ICMP	Common
<input type="checkbox"/>	gateway_icmp		Gateway ICMP	Common
<input type="checkbox"/>	http		HTTP	Common
<input type="checkbox"/>	http_head_f5		HTTP	Common
<input type="checkbox"/>	https		HTTPS	Common
<input type="checkbox"/>	https_443		HTTPS	Common
<input type="checkbox"/>	https_head_f5		HTTPS	Common
<input type="checkbox"/>	icmp		ICMP	Common
<input type="checkbox"/>	inband		Inband	Common

Delete... Page 1 of 2

Assign the Custom Monitor to a Pool Member

From the Navigation pane, click **Local Traffic » Pools** and then click **HTTP-POOL**.
 Click the **Members** tab.
 Click the member **172.16.4.11:80**.

Local Traffic » Pools : Pool List » HTTP-POOL

Configuration section:

Select **Advanced** from the dropdown list.

Address	172.16.4.11
Service Port	80
Partition / Path	Common
Description	<input type="text"/>
Parent Node	<input checked="" type="checkbox"/> 172.16.4.11
Availability	<input checked="" type="radio"/> Available (Enabled) - Pool member is available 2017-05-11 22:59:07
Health Monitors	<input checked="" type="radio"/> http
Monitor Logging	<input type="checkbox"/> Enable
Current Connections	0
State	<input checked="" type="radio"/> Enabled (All traffic allowed) <input type="radio"/> Disabled (Only persistent or active connections allowed) <input type="radio"/> Forced Offline (Only active connections allowed)

Configuration: **Basic** / Advanced

Ratio	<input type="text" value="2"/>
Priority Group	<input type="text" value="4"/>
Connection Limit	<input type="text" value="0"/>
Connection Rate Limit	<input type="text" value="0"/>

Health Monitors: Member Specific

Select Monitors: Select MY-HTTP

Press << button

When complete, click **Update**

Configuration: **Advanced** ▾

Ratio	<input type="text" value="2"/>
Priority Group	<input type="text" value="4"/>
Connection Limit	<input type="text" value="0"/>
Connection Rate Limit	<input type="text" value="0"/>
Health Monitors	None
IP Encapsulation	Inherit From Pool

Configuration: **Advanced** ▾

Ratio	<input type="text" value="2"/>				
Priority Group	<input type="text" value="4"/>				
Connection Limit	<input type="text" value="0"/>				
Connection Rate Limit	<input type="text" value="0"/>				
Health Monitors	Member Specific ▾				
Select Monitors	<table border="1"><thead><tr><th>Active</th><th>Available</th></tr></thead><tbody><tr><td>/Common MY-HTTP</td><td>/Common gateway_icmp http http_head_f5 https</td></tr></tbody></table>	Active	Available	/Common MY-HTTP	/Common gateway_icmp http http_head_f5 https
Active	Available				
/Common MY-HTTP	/Common gateway_icmp http http_head_f5 https				
Availability Requirement	All ▾ Health Monitor(s)				
IP Encapsulation	Inherit From Pool ▾				

Check the members' statuses.

Member Properties	
Node Name	172.16.4.11
Address	172.16.4.11
Service Port	80
Partition / Path	Common
Description	<input type="text"/>
Parent Node	172.16.4.11
Availability	Available (Enabled) - Pool member is available 2017-05-11 22:59:07
Health Monitors	MY-HTTP
Monitor Logging	<input type="checkbox"/> Enable
Current Connections	0
State	<input checked="" type="radio"/> Enabled (All traffic allowed) <input type="radio"/> Disabled (Only persistent or active connections allowed) <input type="radio"/> Forced Offline (Only active connections allowed)

Disassociate all Monitors for Selected Member

From the Navigation pane, click Local Traffic » Pools and click **HTTP-POOL**.

Click the **Members** tab.
 Click the member **172.16.4.12:80**

**Local Traffic » Pools : Pool List » HTTP-POOL
 Configuration section**

Select Advanced from the dropdown list.

Health Monitors: None

When complete, click **Update**

Description	<input type="text"/>
Parent Node	172.16.4.12
Availability	Available (Enabled) - Pool member is available 2017-05-11 22:56:21
Health Monitors	http
Monitor Logging	<input type="checkbox"/> Enable
Current Connections	0
State	<input checked="" type="radio"/> Enabled (All traffic allowed) <input type="radio"/> Disabled (Only persistent or active connections allowed) <input type="radio"/> Forced Offline (Only active connections allowed)

Configuration: **Advanced** ▼

Ratio	<input type="text" value="3"/>
Priority Group	<input type="text" value="4"/>
Connection Limit	<input type="text" value="0"/>
Connection Rate Limit	<input type="text" value="0"/>
Health Monitors	None ▼
IP Encapsulation	Inherit From Pool ▼

Check the member's status

Member Properties	
Node Name	172.16.4.12
Address	172.16.4.12
Service Port	80
Partition / Path	Common
Description	<input type="text"/>
Parent Node	172.16.4.12
Availability	Unknown (Enabled) - Pool member does not have service checking enabled 2017-05-11 23:44:55
Health Monitors	
Monitor Logging	<input type="checkbox"/> Enable
Current Connections	0
State	<input checked="" type="radio"/> Enabled (All traffic allowed) <input type="radio"/> Disabled (Only persistent or active connections allowed) <input type="radio"/> Forced Offline (Only active connections allowed)

Member **172.16.4.10:80** has its health monitor set to inherit from pool, so it inherits an http health monitor.

Description	<input type="text"/>
Parent Node	● 172.16.4.10
Availability	● Available (Enabled) - Pool member is available 2017-05-11 22:59:43
Health Monitors	● http
Monitor Logging	<input type="checkbox"/> Enable
Current Connections	0
State	<input checked="" type="radio"/> Enabled (All traffic allowed) <input type="radio"/> Disabled (Only persistent or active connections allowed) <input type="radio"/> Forced Offline (Only active connections allowed)

Configuration: Advanced

Ratio	<input type="text" value="1"/>
Priority Group	<input type="text" value="0"/>
Connection Limit	<input type="text" value="0"/>
Connection Rate Limit	<input type="text" value="0"/>
Health Monitors	Inherit From Pool <input type="button" value="v"/>
IP Encapsulation	Inherit From Pool <input type="button" value="v"/>

Member **172.16.4.11:80** has a specific monitor assigned: **MY-HTTP**.
Member **172.16.4.12:80** does not have an assigned monitor.

Lab 8: Profiles

Source Address Persistence

Configure a Source Address Affinity persistence profile and assign it to a virtual server
Create a Persistence Profile based on the following:

Local Traffic » Profiles » Persistence » Create

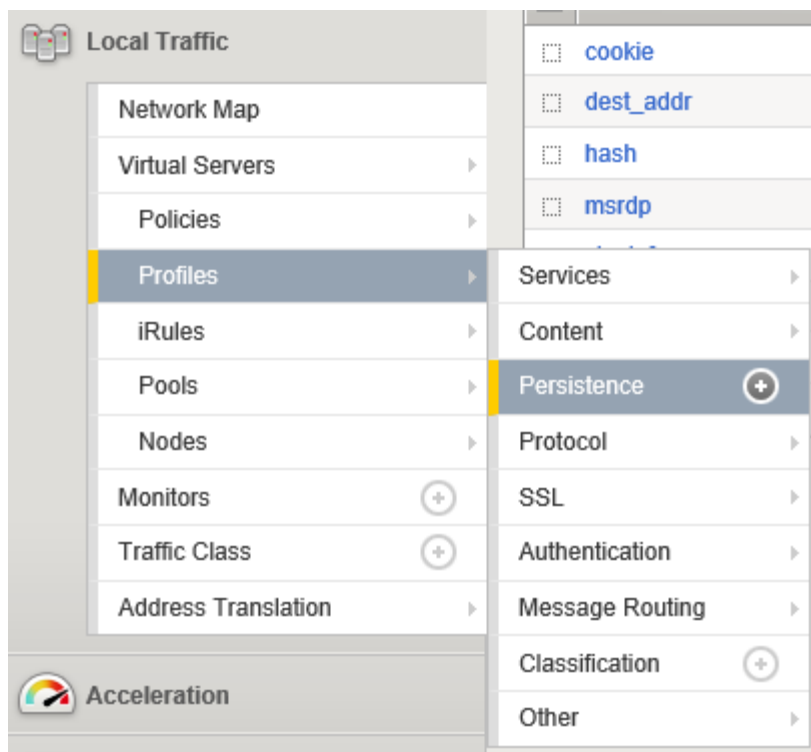

General Properties section:

Name: PR-Source-Add

Persistence Type: Source Address Affinity

Configuration section:

Timeout: Select (check) the Custom checkbox for Timeout and then set Timeout to 30 seconds.

Mask: Click on the Custom checkbox for Mask and specify a network mask of /24.

When complete, click **Finished**

Local Traffic » Profiles : Persistence » **New Persistence Profile...**

General Properties

Name: PR-Source-Add

Persistence Type: Source Address Affinity

Parent Profile: source_addr

Configuration Custom

Match Across Services:

Match Across Virtual Servers:

Match Across Pools:

Hash Algorithm: Default

Timeout: Specify... 30 seconds

Prefix Length: Specify... IPv4 24

Map Proxies: Enabled

Override Connection Limit:

Cancel Repeat Finished

Assign PR-Source-Add to VS-HTTPS

Local Traffic » Virtual Servers » VS-HTTPS » Resources

Local Traffic » Pools : Pool List

Pool List Statistics

* Search Create...

<input checked="" type="checkbox"/>	Status	Name	Description	Application	Members	Partition / Path
<input type="checkbox"/>	●	HTTP-POOL			3	Common
<input type="checkbox"/>	●	HTTPS-POOL			3	Common

Delete...

Load Balancing section:

Default Pool: HTTPS-POOL

Default Persistence Profile: PR-Source-Add

When complete, click **Update**

Local Traffic » Virtual Servers : Virtual Server List » **VS-HTTPS**

Properties Resources Statistics

Load Balancing

Default Pool: HTTPS-POOL

Default Persistence Profile: **None**

Fallback Persistence Profile: PR-Source-Add

Update

iRules Manage...

Name: universal

Local Traffic >> Virtual Servers : Virtual Server List >> VS-HTTPS

Properties Resources **Statistics**

Load Balancing

Default Pool: HTTPS-POOL

Default Persistence Profile: PR-Source-Add

Fallback Persistence Profile: None

Update

Confirm traffic behavior after persistence
 Open a new browser session and connect to <https://10.10.4.101>.
 Refresh the web page five to ten times.
 View the pool **HTTPS-POOL** statistics.

Statistics >> Module Statistics : Local Traffic >> Pools

Traffic Summary DNS Local Traffic **Network** Memory

Display Options

Statistics Type: Pools

Data Format: Normalized

Auto Refresh: Disabled Refresh

/Common/HTTPS-POOL Search Reset Search

		Bits		Packets		Connections			Requests					
✓	▼	Status	▲	Pool	Pool Member	Partition / Path	In	Out	In	Out	Current	Maximum	Total	Total
<input type="checkbox"/>		●	▼	HTTPS-POOL		Common	58.7K	211.9K	58	55	0	2	7	0
<input type="checkbox"/>		●			172.16.4.10:443	Common	58.7K	211.9K	58	55	0	2	7	0
<input type="checkbox"/>		●			172.16.4.11:443	Common	0	0	0	0	0	0	0	0
<input type="checkbox"/>		●			172.16.4.12:443	Common	0	0	0	0	0	0	0	0

Reset

Wait for at least 30 seconds, and then refresh again the <https://10.10.4.101> website again.
 Now the web traffic should be load-balanced to another pool member. Confirm this by refreshing and viewing the pool member statistics.

Statistics » Module Statistics : Local Traffic » Pools																								
Traffic Summary		DNS		Local Traffic		Network		Memory																
Display Options																								
Statistics Type		Pools																						
Data Format		Normalized																						
Auto Refresh		Disabled Refresh																						
/Common/HTTPS-POOL				Search		Reset Search		Bits		Packets		Connections		Requests										
<input checked="" type="checkbox"/>	<input type="checkbox"/>	Status	<input type="checkbox"/>	Pool	<input type="checkbox"/>	Pool Member	<input type="checkbox"/>	Partition / Path	<input type="checkbox"/>	In	<input type="checkbox"/>	Out	<input type="checkbox"/>	In	<input type="checkbox"/>	Out	<input type="checkbox"/>	Current	<input type="checkbox"/>	Maximum	<input type="checkbox"/>	Total	<input type="checkbox"/>	Total
<input type="checkbox"/>	<input checked="" type="checkbox"/>		<input type="checkbox"/>	HTTPS-POOL	<input type="checkbox"/>		<input type="checkbox"/>	Common	<input type="checkbox"/>	58.5K	<input type="checkbox"/>	220.2K	<input type="checkbox"/>	67	<input type="checkbox"/>	66	<input type="checkbox"/>	0	<input type="checkbox"/>	2	<input type="checkbox"/>	10	<input type="checkbox"/>	0
<input type="checkbox"/>	<input checked="" type="checkbox"/>		<input type="checkbox"/>	172.16.4.10:443	<input type="checkbox"/>		<input type="checkbox"/>	Common	<input type="checkbox"/>	0	<input type="checkbox"/>	0	<input type="checkbox"/>	0	<input type="checkbox"/>	0	<input type="checkbox"/>	0	<input type="checkbox"/>	0	<input type="checkbox"/>	0	<input type="checkbox"/>	0
<input type="checkbox"/>	<input checked="" type="checkbox"/>		<input type="checkbox"/>	172.16.4.11:443	<input type="checkbox"/>		<input type="checkbox"/>	Common	<input type="checkbox"/>	58.5K	<input type="checkbox"/>	220.2K	<input type="checkbox"/>	67	<input type="checkbox"/>	66	<input type="checkbox"/>	0	<input type="checkbox"/>	2	<input type="checkbox"/>	10	<input type="checkbox"/>	0
<input type="checkbox"/>	<input checked="" type="checkbox"/>		<input type="checkbox"/>	172.16.4.12:443	<input type="checkbox"/>		<input type="checkbox"/>	Common	<input type="checkbox"/>	0	<input type="checkbox"/>	0	<input type="checkbox"/>	0	<input type="checkbox"/>	0	<input type="checkbox"/>	0	<input type="checkbox"/>	0	<input type="checkbox"/>	0	<input type="checkbox"/>	0
Reset																								

Cookie Persistence

Create a cookie persistence profile and assign it to a virtual server

Create a custom cookie persistence profile named **PR-Cookie**. When you select Cookie as the Persistence Type, the Configuration Section appears. Leave all of the settings in the Configuration section in their default state for now.

Local Traffic » Profiles » Persistence » Create

General Properties section:

Name: PR-Cookie

Persistence Type: Cookie

When complete, click **Finished**

Local Traffic » Profiles : Persistence » **New Persistence Profile...**

General Properties

Name	PR-Cookie x
Persistence Type	Cookie
Parent Profile	cookie

Configuration Custom

Cookie Method	HTTP Cookie Insert	<input type="checkbox"/>
Cookie Name		<input type="checkbox"/>
HTTPOnly Attribute	Enabled	<input type="checkbox"/>
Secure Attribute	Enabled	<input type="checkbox"/>
Always Send Cookie	<input type="checkbox"/>	<input type="checkbox"/>
Expiration	<input checked="" type="checkbox"/> Session Cookie	<input type="checkbox"/>
Cookie Encryption Use Policy	disabled	<input type="checkbox"/>
Encryption Passphrase		<input type="checkbox"/>
Override Connection Limit	<input type="checkbox"/>	<input type="checkbox"/>

Cancel Repeat Finished

Local Traffic » Profiles : Persistence

Services Content Persistence Protocol SSL Authentication

Message Routing Other

Search Create...

<input checked="" type="checkbox"/>	Name	Application	Type	Parent Profile	Partition / Path
<input type="checkbox"/>	PR-Cookie		Cookie	cookie	Common
<input type="checkbox"/>	PR-Source-Add		Source Address Affinity	source_addr	Common
<input type="checkbox"/>	cookie		Cookie	(none)	Common
<input type="checkbox"/>	dest_addr		Destination Address Affinity	(none)	Common
<input type="checkbox"/>	hash		Hash	(none)	Common
<input type="checkbox"/>	msrdp		Microsoft® Remote Desktop	(none)	Common
<input type="checkbox"/>	sip_info		SIP	(none)	Common
<input type="checkbox"/>	source_addr		Source Address Affinity	(none)	Common
<input type="checkbox"/>	ssl		SSL	(none)	Common
<input type="checkbox"/>	universal		Universal	(none)	Common

Delete...

Assign PR-Cookie to VS-HTTP.

Local Traffic » Virtual Servers » VS-HTTP » Resources

Load Balancing section:

Default Pool: HTTP-POOL

Default Persistence Profile: PR-Cookie

When complete, click **Update**

Local Traffic » Virtual Servers : Virtual Server List » VS-HTTP

Properties Resources **Statistics**

Load Balancing

Default Pool	HTTP-POOL
Default Persistence Profile	PR-Cookie
Fallback Persistence Profile	None

Update

Don't forget to modify **VS-HTTP** to include an **HTTP Profile** and repeat the step above.

Configuration: Basic

Protocol	TCP
Protocol Profile (Client)	tcp
Protocol Profile (Server)	(Use Client Profile)
HTTP Profile	http
FTP Profile	None
RTSP Profile	None
SSH Proxy Profile	None

Confirm traffic behavior after persistence

Access and reset the statistics for **HTTP-POOL**.

On the browser connect to **http://10.10.4.100**, refresh the screen 5 to 10 times.

View the pool statistics.

All traffic is directed to one member.

Statistics » Module Statistics : Local Traffic » Pools

Traffic Summary DNS Local Traffic **Network** Memory

Display Options

Statistics Type: Pools

Data Format: Normalized

Auto Refresh: Disabled Refresh

		Search		Reset Search		Bits		Packets		Connections			Requests
✓	▼ Status	▲ Pool	◆ Pool Member	◆ Partition / Path	◆ In	◆ Out	◆ In	◆ Out	◆ Current	◆ Maximum	◆ Total	◆ Total	
<input type="checkbox"/>	●	HTTP-POOL		Common	95.1K	425.2K	130	128	0	2	19	19	
<input type="checkbox"/>	●		172.16.4.10:80	Common	95.1K	425.2K	130	128	0	2	19	19	
<input type="checkbox"/>	●		172.16.4.11:80	Common	0	0	0	0	0	0	0	0	
<input type="checkbox"/>	●		172.16.4.12:80	Common	0	0	0	0	0	0	0	0	

Reset

Lab 9: Client SSL

Create an SSL Certificate

Create a custom SSL Certificate.

System » File Management : SSL Certificate List » click Create.

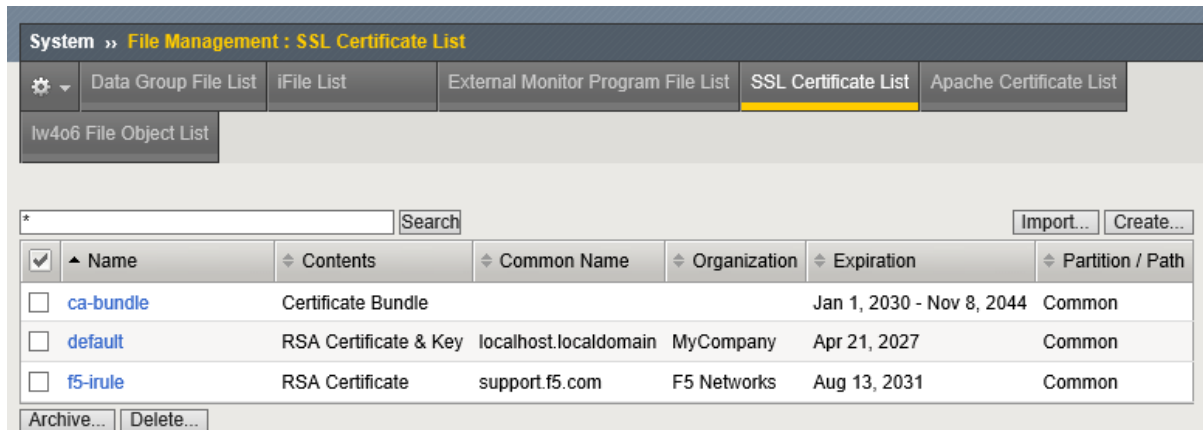

The screenshot shows a management console interface for SSL certificates. At the top, there is a breadcrumb trail: "System » File Management : SSL Certificate List". Below this, there are several tabs: "Data Group File List", "iFile List", "External Monitor Program File List", "SSL Certificate List" (which is highlighted), and "Apache Certificate List". Underneath the tabs, there is a sub-tab "lw4o6 File Object List". A search bar with a "Search" button is present. To the right of the search bar are "Import..." and "Create..." buttons. Below the search bar is a table with the following columns: "Name", "Contents", "Common Name", "Organization", "Expiration", and "Partition / Path". The table contains three rows of certificates:

<input checked="" type="checkbox"/>	Name	Contents	Common Name	Organization	Expiration	Partition / Path
<input type="checkbox"/>	ca-bundle	Certificate Bundle			Jan 1, 2030 - Nov 8, 2044	Common
<input type="checkbox"/>	default	RSA Certificate & Key	localhost.localdomain	MyCompany	Apr 21, 2027	Common
<input type="checkbox"/>	f5-irule	RSA Certificate	support.f5.com	F5 Networks	Aug 13, 2031	Common

At the bottom of the table, there are "Archive..." and "Delete..." buttons.

General Properties section:

Name: Self-Signed-Cert

Certificate Properties section:

Issuer: Self

Common Name: www.test.com

Division: IT Division

Organization: Test Organization

Locality: Algiers

State or Province: Algiers

Country: Algeria

E-mail Address: Leave blank

Lifetime: 365

Key Properties section: Size 2048

When complete, click **Finished**

System » File Management : SSL Certificate List » New SSL Certificate...

General Properties

Name: Self-Signed-Cert

Certificate Properties

Issuer: Self

Common Name: www.test.com

Division: IT Division

Organization: Test Organization

Locality: Algiers

State Or Province: Algiers

Country: Algeria DZ

E-mail Address:

Lifetime: 365 days

Subject Alternative Name:

Key Properties

Security Type: Normal

Key Type: RSA

Size: 2048 bits

Cancel Finished

System » File Management : SSL Certificate List

Data Group File List iFile List External Monitor Program File List **SSL Certificate List** Apache Certificate List

Iw4o6 File Object List

* Search Import... Create...

<input checked="" type="checkbox"/>	Name	Contents	Common Name	Organization	Expiration	Partition / Path
<input type="checkbox"/>	Self-Signed-Cert	RSA Certificate & Key	www.test.com	Test Organization	May 13, 2018	Common
<input type="checkbox"/>	ca-bundle	Certificate Bundle			Jan 1, 2030 - Nov 8, 2044	Common
<input type="checkbox"/>	default	RSA Certificate & Key	localhost.localdomain	MyCompany	Apr 21, 2027	Common
<input type="checkbox"/>	f5-irule	RSA Certificate	support.f5.com	F5 Networks	Aug 13, 2031	Common

Archive... Delete...

Create an SSL Profile

Create a Client SSL profile called SSL-Client-Profile with clientssl as its parent.

Local Traffic » Profiles » SSL » Client and click Create.

The screenshot shows the F5 BIG-IP configuration interface. On the left, the 'Local Traffic' navigation tree is expanded to 'Profiles' > 'SSL'. On the right, a table lists several SSL profiles:

<input checked="" type="checkbox"/>	Name	Contents	Common Name
<input type="checkbox"/>	Self-Signed-Cert	RSA Certificate & Key	www.test.com
<input type="checkbox"/>	ca-bundle	Certificate Bundle	
<input type="checkbox"/>	default	RSA Certificate & Key	localhost.localdomain
<input type="checkbox"/>	f5-irule	RSA Certificate	support.f5.com

The screenshot shows the configuration page for the 'SSL : Client' profile. The breadcrumb is 'Local Traffic >> Profiles : SSL : Client'. The configuration page includes a search bar and a table of existing client profiles:

<input checked="" type="checkbox"/>	Name	Application	Parent Profile	Partition / Path
<input type="checkbox"/>	clientssl		(none)	Common
<input type="checkbox"/>	clientssl-insecure-compatible		clientssl	Common
<input type="checkbox"/>	clientssl-secure		clientssl	Common
<input type="checkbox"/>	crypto-server-default-clientssl		clientssl	Common
<input type="checkbox"/>	wom-default-clientssl		clientssl	Common

General Properties section:

Name: SSL-Client-Profile

Parent Profile: clientssl

Configuration section:

Certificate Key Chain: Add the Self-Signed-Cert created previously

Local Traffic » Profiles : SSL : Client » **New Client SSL Profile...**

General Properties

Name	SSL-Client-Profile
Parent Profile	clientsssl

Configuration: Basic Custom

Certificate Key Chain	<input checked="" type="checkbox"/>
Proxy SSL	<input type="checkbox"/>
Proxy SSL Passthrough	<input type="checkbox"/>

Add SSL Certificate to Key Chain

Certificate	Self-Signed-Cert
Key	Self-Signed-Cert
Chain	Self-Signed-Cert
Passphrase	
OCSP Stapling	None

Local Traffic » Profiles : SSL : Client » **New Client SSL Profile...**

General Properties

Name	SSL-Client-Profile
Parent Profile	clientsssl

Configuration: Basic Custom

Certificate Key Chain	/Common/Self-Signed-Cert.crt /Common/Self-Signed-Cert.key /Common/Self-Signed-Cert.crt <input checked="" type="checkbox"/>
Proxy SSL	<input type="checkbox"/>
Proxy SSL Passthrough	<input type="checkbox"/>

When complete, click **Finished**

SSL Forward Proxy: Basic Custom

SSL Forward Proxy	Disabled <input type="checkbox"/>
CA Certificate	Select... <input type="checkbox"/>
CA Key	Select... <input type="checkbox"/>
Certificate Lifespan	30 day(s) <input type="checkbox"/>
Certificate Extensions	Extensions List... <input type="checkbox"/>
Certificate Extensions List	<p>Enabled Extensions</p> <ul style="list-style-type: none"> Basic Constraints Subject Alternative Name <p>Disable</p> <p>Available extensions</p> <ul style="list-style-type: none"> Authority Key Identifier Certificate Policies CRL Distribution Points Extended Key Usage Fresh CRL (a.k.a. Delta CRL Distribution Point) <p>Enable</p>
Cache Certificate by Addr-Port	<input type="checkbox"/>
SSL Forward Proxy Bypass	Disabled <input type="checkbox"/>

Cancel Repeat Finished

Local Traffic » Profiles : SSL : Client

Services Content Persistence Protocol SSL

Authentication Message Routing Other

* Search Create...

<input checked="" type="checkbox"/>	Name	Application	Parent Profile	Partition / Path
<input type="checkbox"/>	SSL-Client-Profile		clientssl	Common
<input type="checkbox"/>	clientssl		(none)	Common
<input type="checkbox"/>	clientssl-insecure-compatible		clientssl	Common
<input type="checkbox"/>	clientssl-secure		clientssl	Common
<input type="checkbox"/>	crypto-server-default-clientssl		clientssl	Common
<input type="checkbox"/>	wom-default-clientssl		clientssl	Common

Delete...

Create a New Virtual Server

Create a new virtual server called VS-SSL with an IP address of 10.10.4.104:443 and assign pool HTTP-POOL as its default pool.

Local Traffic » Virtual Servers » Virtual Server List, then click Create

Local Traffic » Virtual Servers : Virtual Server List

Virtual Server List Virtual Address List Statistics

* Search Create...

<input checked="" type="checkbox"/>	Status	Name	Description	Application	Destination	Service Port	Type	Resources	Partition / Path
<input type="checkbox"/>	●	VS-HTTP			10.10.4.100	80 (HTTP)	Standard	Edit..	Common
<input type="checkbox"/>	◆	VS-HTTPS			10.10.4.101	443 (HTTPS)	Standard	Edit..	Common

Enable Disable Delete...

General Properties section:

Name: VS-SSL

Destination Type: Standard

Address: 10.10.4.104

Service Port: 443 (or type or select HTTPS)

State: Enabled

Local Traffic » Virtual Servers : Virtual Server List » New Virtual Server...

General Properties

Name	<input type="text" value="VS-SSL"/>
Description	<input type="text"/>
Type	Standard <input type="button" value="v"/>
Source Address	<input type="text"/>
Destination Address/Mask	<input type="text" value="10.10.4.104"/>
Service Port	<input type="text" value="443"/> <input type="button" value="v"/> HTTPS
Notify Status to Virtual Address	<input checked="" type="checkbox"/>
State	Enabled <input type="button" value="v"/>

Configuration section:

SSL Profile (Client): SSL-Client-Profile

Configuration: Basic

Protocol	TCP				
Protocol Profile (Client)	tcp				
Protocol Profile (Server)	(Use Client Profile)				
HTTP Profile	None				
FTP Profile	None				
RTSP Profile	None				
SSH Proxy Profile	None				
SSL Profile (Client)	<table border="1"> <thead> <tr> <th>Selected</th> <th>Available</th> </tr> </thead> <tbody> <tr> <td>/Common SSL-Client-Profile</td> <td> <ul style="list-style-type: none"> clientssl clientssl-insecure-compatible clientssl-secure crypto-server-default-clientssl wom-default-clientssl </td> </tr> </tbody> </table>	Selected	Available	/Common SSL-Client-Profile	<ul style="list-style-type: none"> clientssl clientssl-insecure-compatible clientssl-secure crypto-server-default-clientssl wom-default-clientssl
Selected	Available				
/Common SSL-Client-Profile	<ul style="list-style-type: none"> clientssl clientssl-insecure-compatible clientssl-secure crypto-server-default-clientssl wom-default-clientssl 				

Resources section:

Default Pool: HTTP-POOL

When complete, click **Finished**

Resources

iRules	<table border="1"> <thead> <tr> <th>Enabled</th> <th>Available</th> </tr> </thead> <tbody> <tr> <td></td> <td> <ul style="list-style-type: none"> /Common _sys_APM_ExchangeSupport_OA_BasicAuth _sys_APM_ExchangeSupport_OA_NtlmAuth _sys_APM_ExchangeSupport_helper _sys_APM_ExchangeSupport_main </td> </tr> </tbody> </table>	Enabled	Available		<ul style="list-style-type: none"> /Common _sys_APM_ExchangeSupport_OA_BasicAuth _sys_APM_ExchangeSupport_OA_NtlmAuth _sys_APM_ExchangeSupport_helper _sys_APM_ExchangeSupport_main
Enabled	Available				
	<ul style="list-style-type: none"> /Common _sys_APM_ExchangeSupport_OA_BasicAuth _sys_APM_ExchangeSupport_OA_NtlmAuth _sys_APM_ExchangeSupport_helper _sys_APM_ExchangeSupport_main 				
Policies	<table border="1"> <thead> <tr> <th>Enabled</th> <th>Available</th> </tr> </thead> <tbody> <tr> <td></td> <td></td> </tr> </tbody> </table>	Enabled	Available		
Enabled	Available				
Default Pool	HTTP-POOL				
Default Persistence Profile	None				
Fallback Persistence Profile	None				

Cancel Repeat Finished

Local Traffic >> Virtual Servers : Virtual Server List

Virtual Server List Virtual Address List Statistics

* Search Create...

✓	Status	Name	Description	Application	Destination	Service Port	Type	Resources	Partition / Path
<input type="checkbox"/>	●	VS-HTTP			10.10.4.100	80 (HTTP)	Standard	Edit...	Common
<input type="checkbox"/>	◆	VS-HTTPS			10.10.4.101	443 (HTTPS)	Standard	Edit...	Common
<input type="checkbox"/>	●	VS-SSL			10.10.4.104	443 (HTTPS)	Standard	Edit...	Common

Enable Disable Delete...

In Web browser of the external client, go to <https://10.10.4.104>. If prompted, accept the SSL certificate.

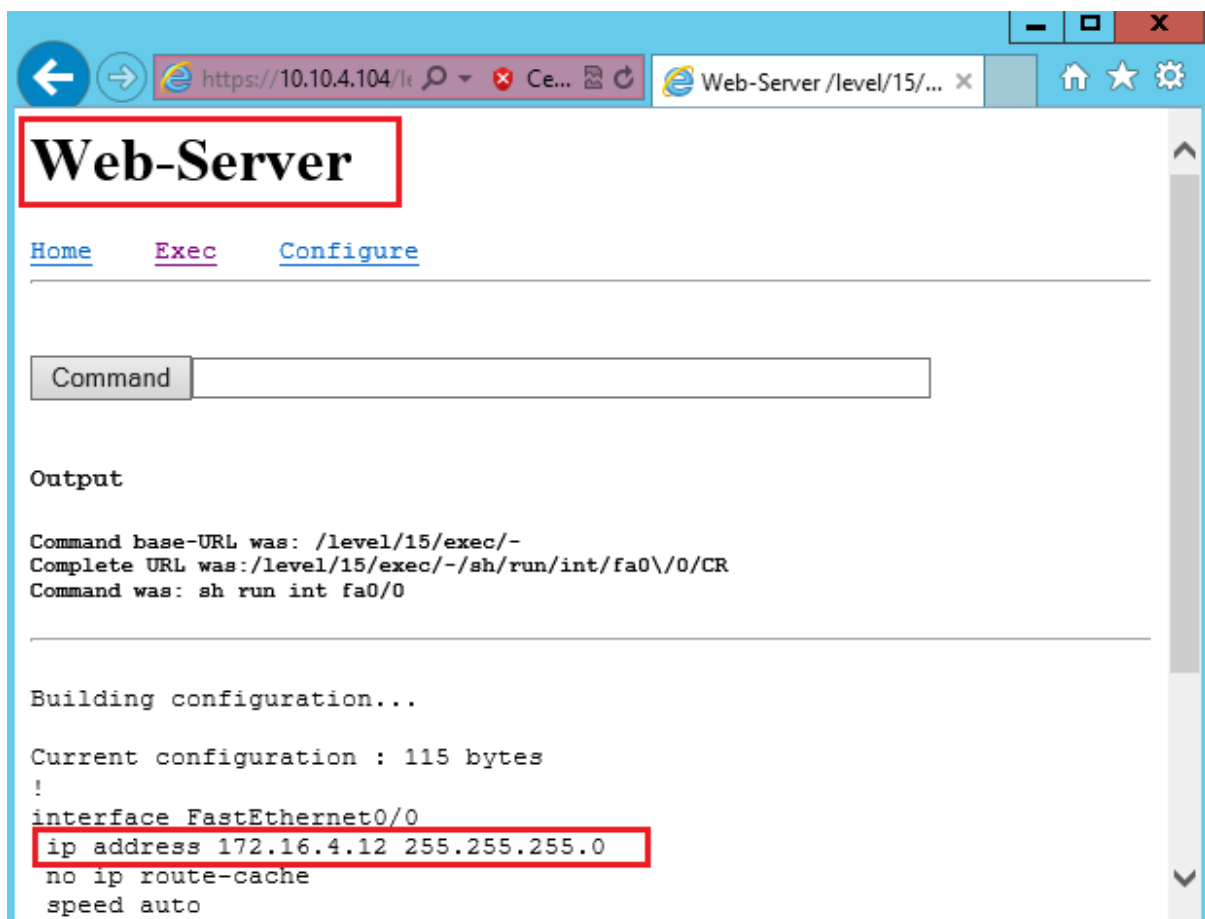
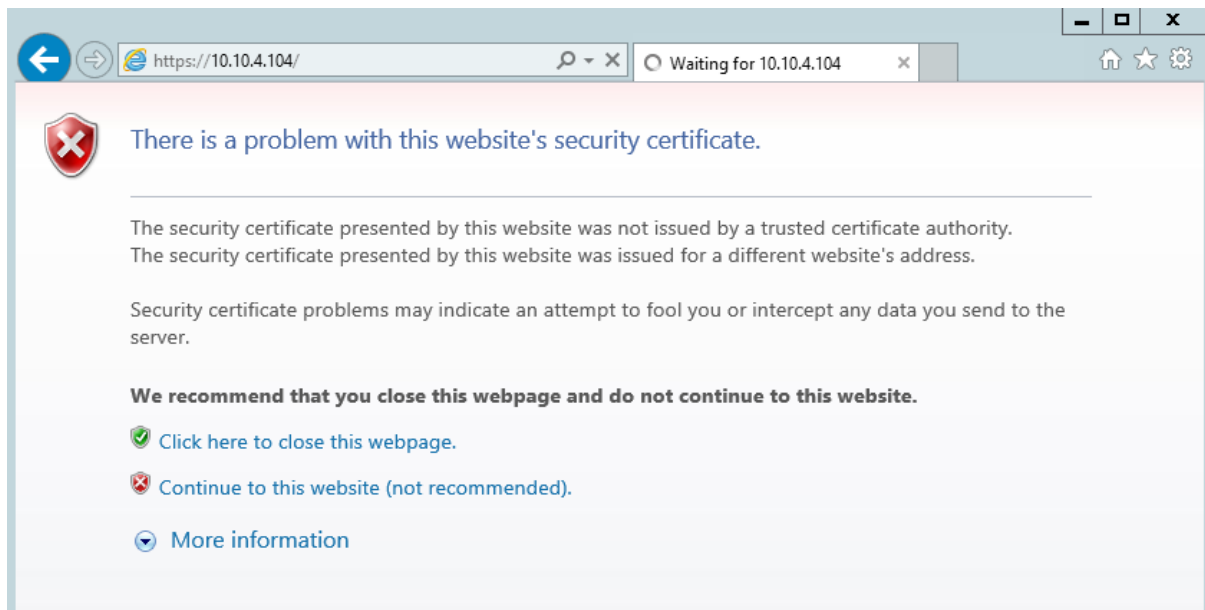

In the web browser, view the certificate.

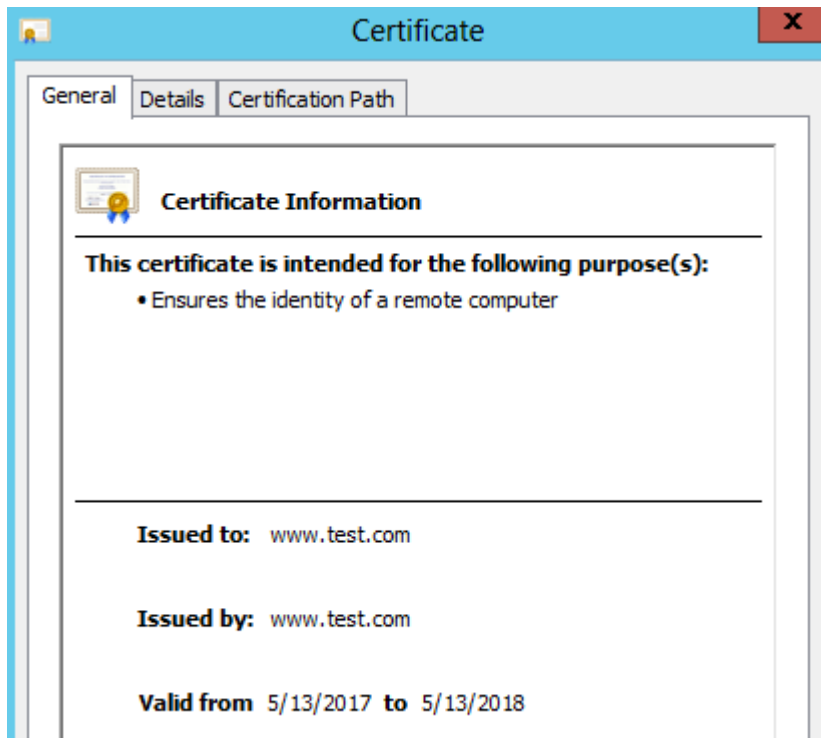

Traffic is encrypted from client to the BIG-IP system, but unencrypted between the BIG-IP and the pool members.

Lab 10: iRules

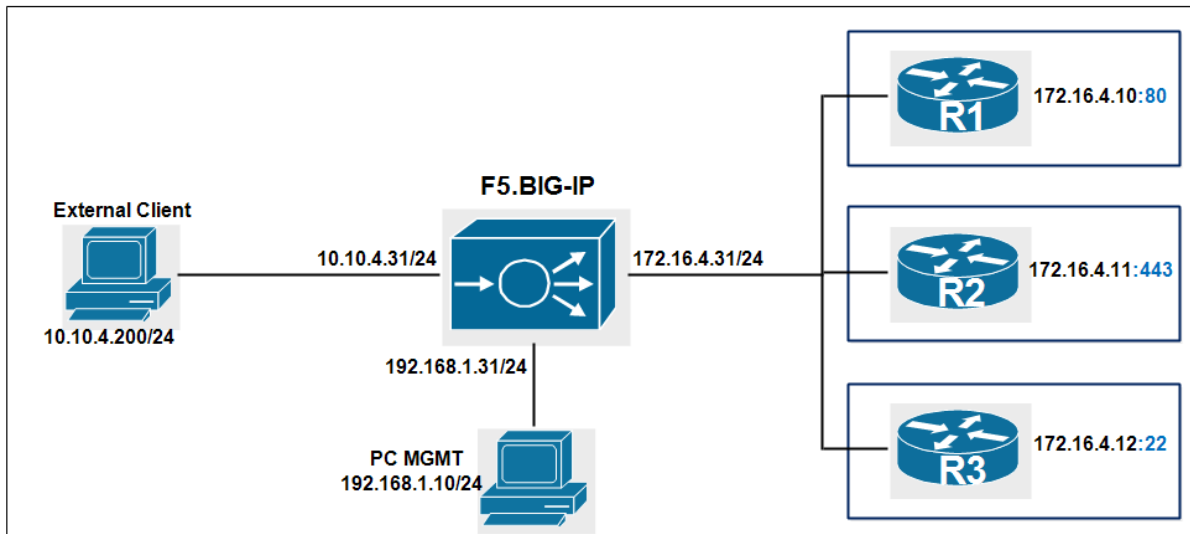

R1 is running HTTP.
R2 is running HTTPS.
R3 is running SSH.

The HTTP traffic initiated by the External Client should be redirected to R1.
The HTTPS traffic initiated by the External Client should be redirected to R2.
The SSH traffic initiated by the External Client should be redirected to R3.

Create pools for application services deployment

In **Local Traffic » Pools**, create three new pools.

1. Create **POOL-1** that contains one member, **172.16.4.10:*** (Port is "All services")
2. Create **POOL-2** that contains one member, **172.16.4.11:*** (Port is "All services")
3. Create **POOL-3** that contains one member, **172.16.4.12:*** (Port is "All services")

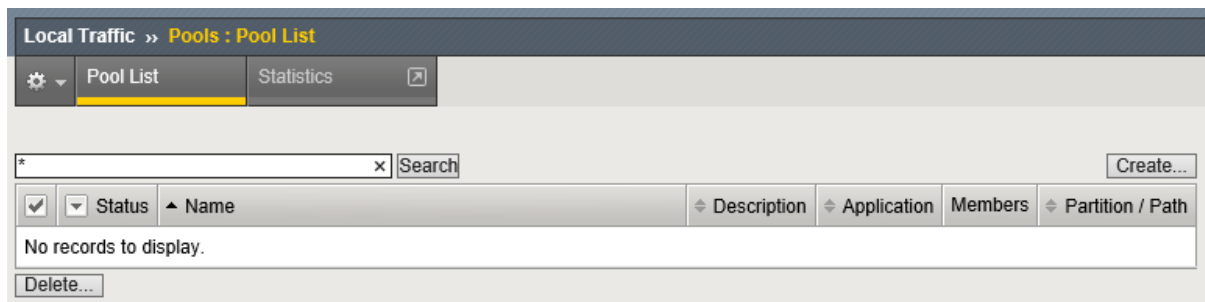

Creation of **POOL-1**.

Name	POOL-1				
Description					
Health Monitors	<table border="1"> <thead> <tr> <th>Active</th> <th>Available</th> </tr> </thead> <tbody> <tr> <td>/Common gateway_icmp</td> <td>https_head_f5 inband tcp tcp_half_open udp</td> </tr> </tbody> </table>	Active	Available	/Common gateway_icmp	https_head_f5 inband tcp tcp_half_open udp
Active	Available				
/Common gateway_icmp	https_head_f5 inband tcp tcp_half_open udp				
Resources					
Load Balancing Method	Round Robin				
Priority Group Activation	Disabled				
New Members	<p> <input checked="" type="radio"/> New Node <input type="radio"/> New FQDN Node <input type="radio"/> Node List </p> <p> Node Name: <input type="text"/> (Optional) </p> <p> Address: <input type="text" value="172.16.4.10"/> </p> <p> Service Port: <input type="text" value="*"/> <input type="text" value="* All Services"/> </p> <p><input type="button" value="Add"/></p> <p>R:1 P:0 C:0 172.16.4.10 172.16.4.10 :*</p> <p><input type="button" value="Edit"/> <input type="button" value="Delete"/></p>				
<input type="button" value="Cancel"/> <input type="button" value="Repeat"/> <input type="button" value="Finished"/>					

Creation of **POOL-2**.

Name	POOL-2				
Description					
Health Monitors	<table border="1"> <thead> <tr> <th>Active</th> <th>Available</th> </tr> </thead> <tbody> <tr> <td>/Common gateway_icmp</td> <td>/Common MY-HTTP http http_head_f5 https</td> </tr> </tbody> </table>	Active	Available	/Common gateway_icmp	/Common MY-HTTP http http_head_f5 https
Active	Available				
/Common gateway_icmp	/Common MY-HTTP http http_head_f5 https				
Resources					
Load Balancing Method	Round Robin				
Priority Group Activation	Disabled				
New Members	<p> <input checked="" type="radio"/> New Node <input type="radio"/> New FQDN Node <input type="radio"/> Node List </p> <p> Node Name: <input type="text"/> (Optional) </p> <p> Address: <input type="text" value="172.16.4.11"/> </p> <p> Service Port: <input type="text" value="*"/> <input type="text" value="* All Services"/> </p> <p><input type="button" value="Add"/></p> <p>R:1 P:0 C:0 172.16.4.11 172.16.4.11 :*</p> <p><input type="button" value="Edit"/> <input type="button" value="Delete"/></p>				
<input type="button" value="Cancel"/> <input type="button" value="Repeat"/> <input type="button" value="Finished"/>					

Creation of **POOL-3**.

Name	POOL-3
Description	
Health Monitors	<div style="display: flex; justify-content: space-between;"> <div style="border: 1px solid gray; padding: 2px;"> <p>Active</p> <p>/Common gateway_icmp</p> </div> <div style="border: 1px solid gray; padding: 2px;"> <p>Available</p> <p>/Common MY-HTTP http http_head_f5 https</p> </div> </div>
Resources	
Load Balancing Method	Round Robin
Priority Group Activation	Disabled
New Members	<p><input checked="" type="radio"/> New Node <input type="radio"/> New FQDN Node <input type="radio"/> Node List</p> <p>Node Name: <input type="text"/> (Optional)</p> <p>Address: <input type="text" value="172.16.4.12"/> x</p> <p>Service Port: <input type="text" value="*"/> * All Services</p> <p><input type="button" value="Add"/></p> <p>R:1 P:0 C:0 172.16.4.12 172.16.4.12 :*</p> <p><input type="button" value="Edit"/> <input type="button" value="Delete"/></p>
<input type="button" value="Cancel"/> <input type="button" value="Repeat"/> <input type="button" value="Finished"/>	

Local Traffic » Pools : Pool List

Pool List

* Search

<input checked="" type="checkbox"/>	Status	Name	Description	Application	Members	Partition / Path
<input type="checkbox"/>	●	POOL-1			1	Common
<input type="checkbox"/>	●	POOL-2			1	Common
<input type="checkbox"/>	●	POOL-3			1	Common

Create an iRule to check TCP port

Navigate to Local Traffic and create an iRule as follows:

Local Traffic » iRules : iRule List then click **Create**

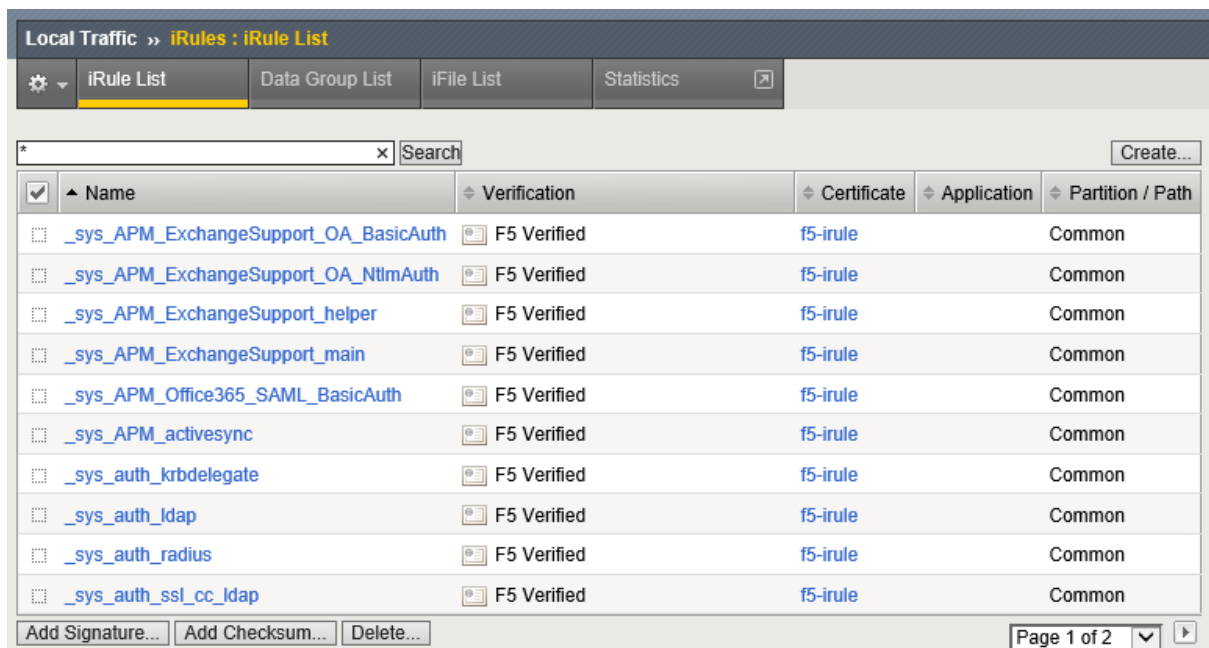
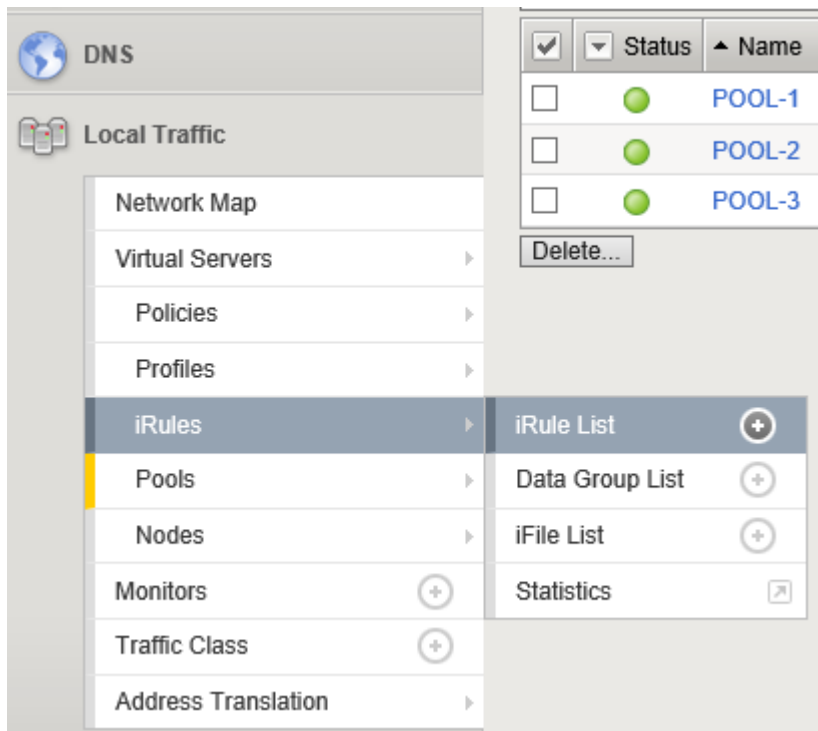

General Properties section:

Name: Rule-For-TCP

Definition:

```
when CLIENT_ACCEPTED {
  if {[TCP::local_port] == 80} {
    pool pool1
  }
  elseif {[TCP::local_port] == 443} {
```

```

pool pool2
}
}

```

When complete, click **Finished**

Local Traffic » iRules : iRule List » New iRule...

Properties

Name: Rule-For-TCP

Definition:

```

1 when CLIENT_ACCEPTED {
2   if {[TCP::local_port] == 80} {
3     pool POOL-1
4   }
5   elseif {[TCP::local_port] == 443} {
6     pool POOL-2
7   }
8 }

```

Wrap Text
 Show Print Margin

Cancel Finished

Local Traffic » iRules : iRule List

iRule List Data Group List iFile List Statistics

Search Create...

<input checked="" type="checkbox"/>	Name	Verification	Certificate	Application	Partition / Path
<input type="checkbox"/>	Rule-For-TCP	None			Common
<input type="checkbox"/>	__sys_APM_ExchangeSupport_OA_BasicAuth	F5 Verified	f5-irule		Common
<input type="checkbox"/>	__sys_APM_ExchangeSupport_OA_NtlmAuth	F5 Verified	f5-irule		Common
<input type="checkbox"/>	__sys_APM_ExchangeSupport_helper	F5 Verified	f5-irule		Common
<input type="checkbox"/>	__sys_APM_ExchangeSupport_main	F5 Verified	f5-irule		Common
<input type="checkbox"/>	__sys_APM_Office365_SAML_BasicAuth	F5 Verified	f5-irule		Common
<input type="checkbox"/>	__sys_APM_activesync	F5 Verified	f5-irule		Common
<input type="checkbox"/>	__sys_auth_krbdelegate	F5 Verified	f5-irule		Common
<input type="checkbox"/>	__sys_auth_ldap	F5 Verified	f5-irule		Common
<input type="checkbox"/>	__sys_auth_radius	F5 Verified	f5-irule		Common

Add Signature... Add Checksum... Delete... Page 1 of 2

Create a virtual server that uses this iRule:

Local Traffic » Virtual Servers : Virtual Server List then click **Create**

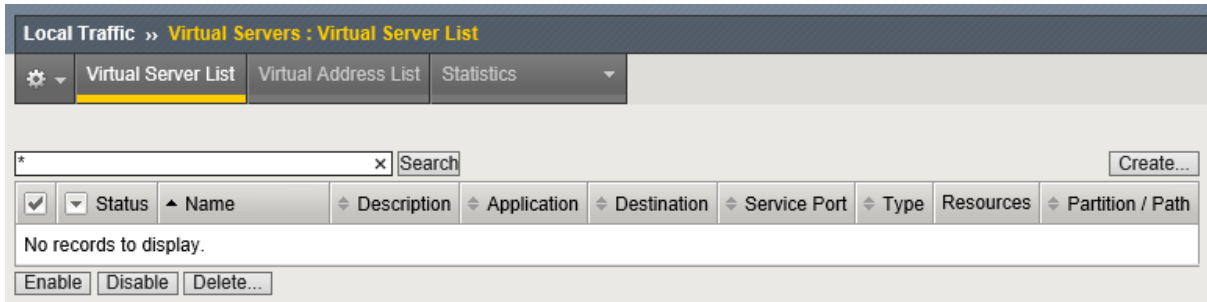

General Properties section:

Name: VS-For-iRule

Destination: 10.10.1.103

Service Port: *All Ports

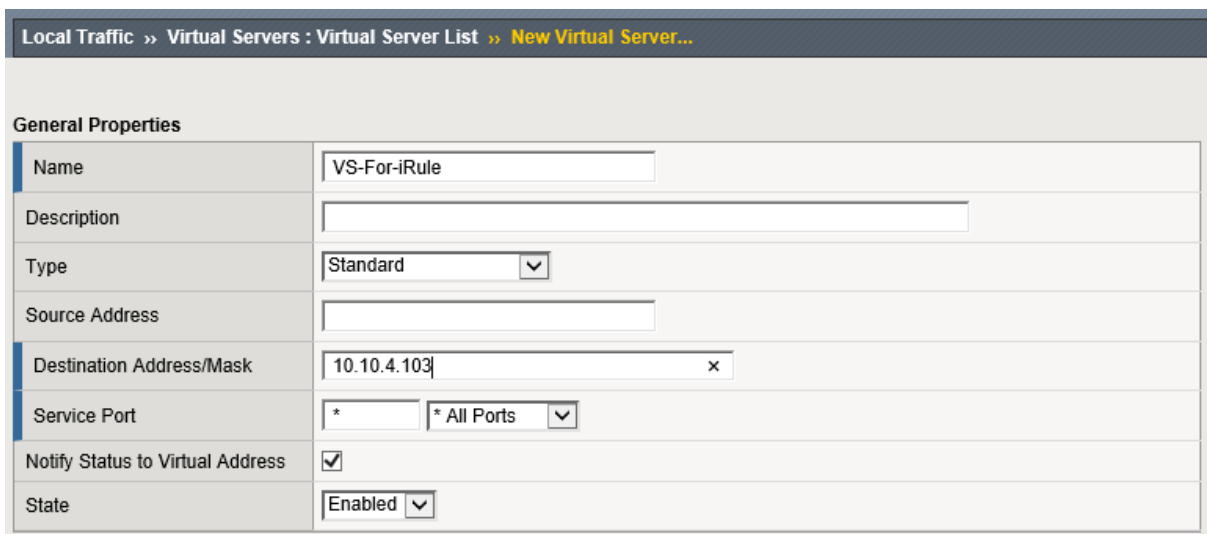

Resources section:

iRules: Rule-For-TCP

Default Pool: POOL-3

When complete, click **Finished**

Resources

iRules	Enabled	Available
	<input type="text" value="/Common"/> <input type="text" value="Rule-For-TCP"/>	<input type="text" value="/Common"/> <input type="text" value="_sys_APM_ExchangeSupport_OA_BasicAuth"/> <input type="text" value="_sys_APM_ExchangeSupport_OA_NtlmAuth"/> <input type="text" value="_sys_APM_ExchangeSupport_helper"/> <input type="text" value="_sys_APM_ExchangeSupport_main"/>
Policies	Enabled	Available
Default Pool	+ POOL-3	
Default Persistence Profile	None	
Fallback Persistence Profile	None	

Cancel Repeat Finished

Local Traffic » Virtual Servers : Virtual Server List

Virtual Server List Virtual Address List Statistics

* Search Create...

<input type="checkbox"/>	Status	Name	Description	Application	Destination	Service Port	Type	Resources	Partition / Path
<input type="checkbox"/>	●	VS-For-iRule			10.10.4.103	0 (Any)	Standard	Edit...	Common

Enable Disable Delete...

Verify behavior through statistics

Open a new browser session on the **external PC** and type the URL <http://10.10.1.103>. The **HTTP** traffic should be redirected to the node **172.16.4.10** which is the router **R1**.

http://10.10.4.103/ R1 Home Page

Cisco Systems

Accessing Cisco 7206VXR "R1"

- [Show diagnostic log](#) - display the diagnostic log.
- [Monitor the router](#) - HTML access to the command line interface at level [0,1,2,3,4,5,6,7,8,9,10,11,12,13,14,15](#)
- [Platform](#) - platform utilities. Send comments to cs-html (below).
- [Show tech-support](#) - display information commonly needed by tech support.
- [Extended Ping](#) - Send extended ping commands.
- [QoS Device Manager](#) - Configure and monitor QoS through the web interface.

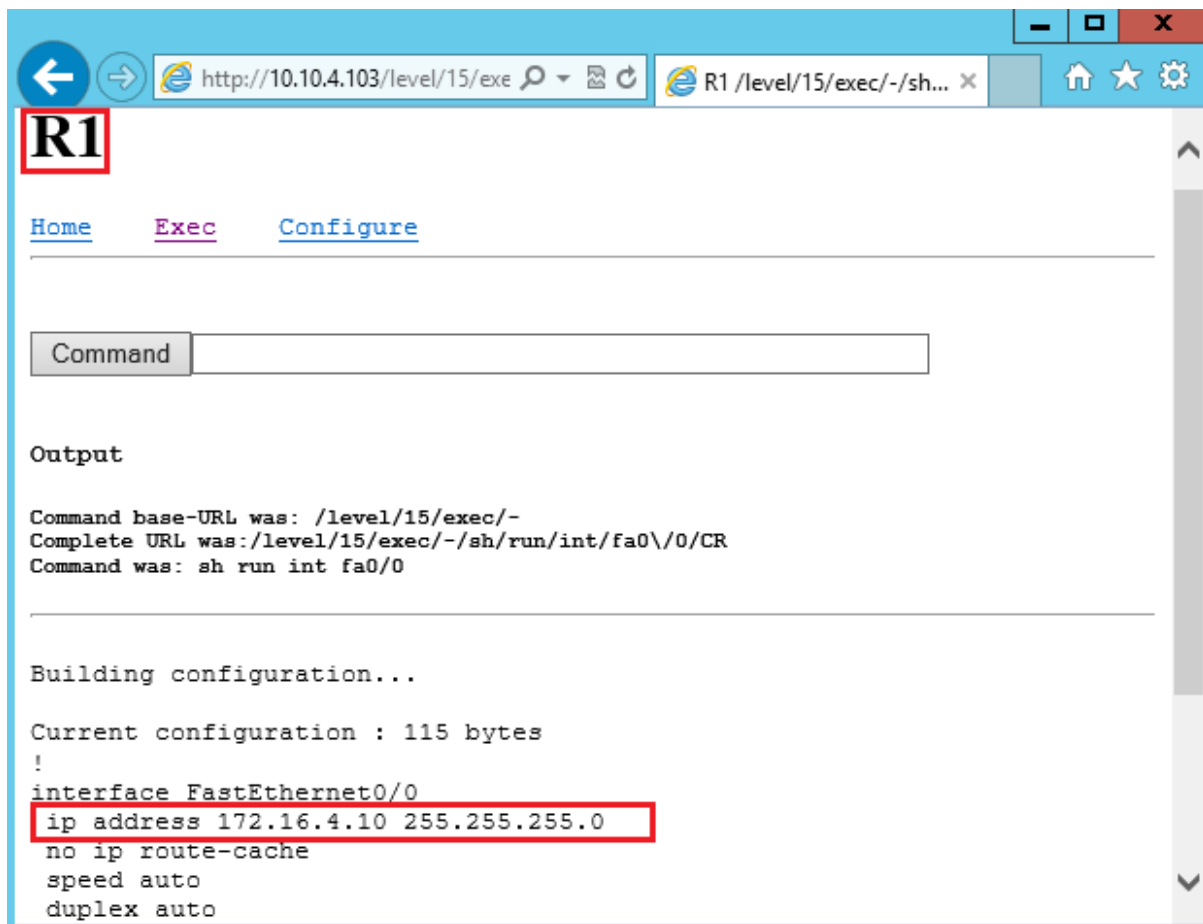

View statistics and configuration information in the Pools.

Since the node **172.16.4.10** belongs to the **POOL-1**, the number of the **bits** and the **packets** is increased.

Statistics » Module Statistics : Local Traffic » Pools

Traffic Summary DNS Local Traffic Network Memory

Display Options

Statistics Type: Pools

Data Format: Normalized

Auto Refresh: Disabled Refresh

Search

	Status	Pool	Pool Member	Partition / Path	Bits		Packets		Connections		
					In	Out	In	Out	Current	Maximum	Total
<input type="checkbox"/>	●	POOL-1		Common	4.3K	18.6K	6	6	1	2	2
<input type="checkbox"/>	●	POOL-2		Common	0	0	0	0	0	0	0
<input type="checkbox"/>	●	POOL-3		Common	0	0	0	0	0	0	0

Reset

Open a new browser session on the **external PC** and type the URL <https://10.10.1.103>. The **HTTPs** traffic should be redirected to the node **172.16.4.11** which is the router **R2**.

https://10.10.4.103/ R2 Home Page

Cisco Systems

Accessing Cisco 7206VXR "R2"

[Show diagnostic log](#) - display the diagnostic log.

[Monitor the router](#) - HTML access to the command line interface at level [0,1,2,3,4,5,6,7,8,9,10,11,12,13,14,15](#)

[Platform](#) - platform utilities. Send comments to cs-html (below).

[Show tech-support](#) - display information commonly needed by tech support.

[Extended Ping](#) - Send extended ping commands.

[QoS Device Manager](#) - Configure and monitor QoS through the web interface.

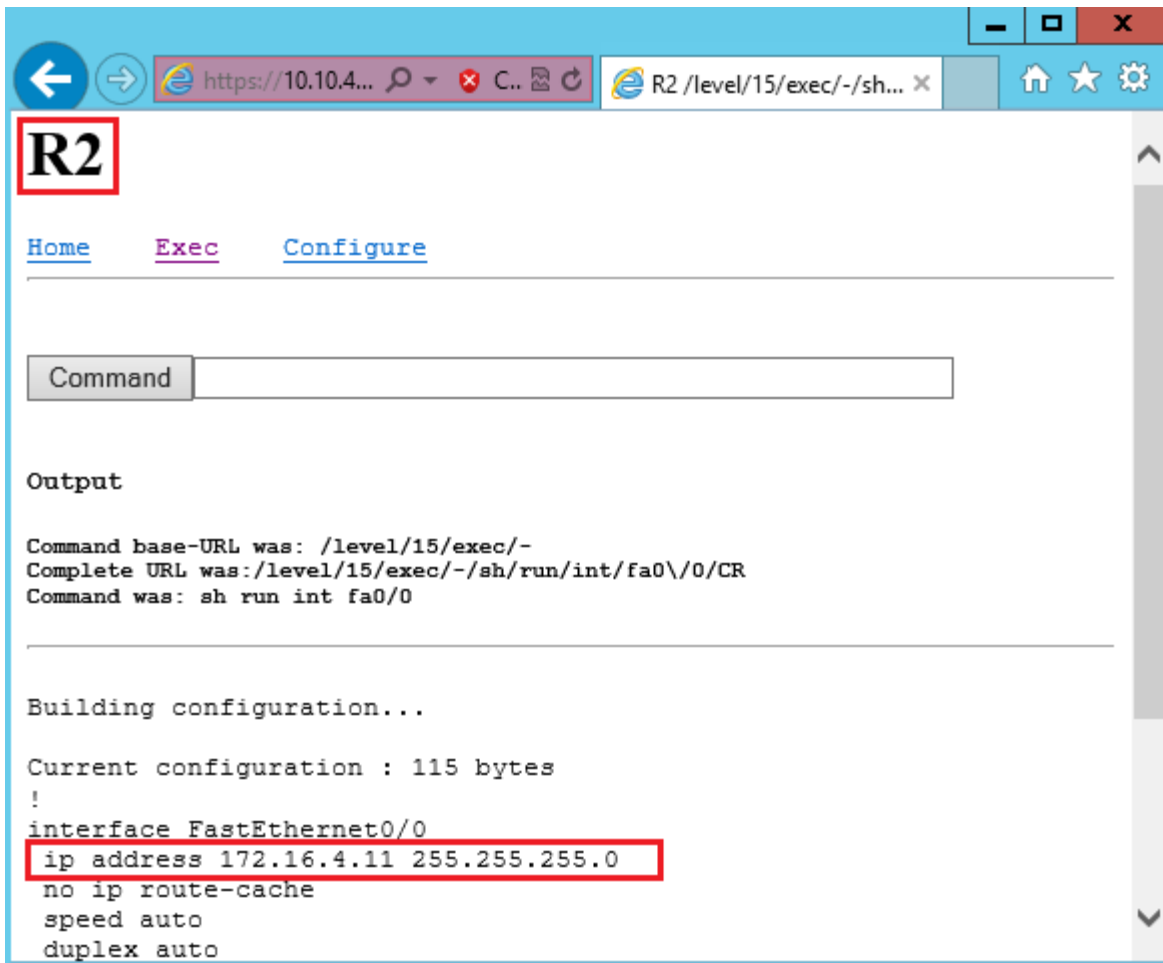

View statistics and configuration information in the Pools.

Since the node **172.16.4.11** belongs to the **POOL-2**, the number of the **bits** and the **packets** is increased.

Statistics » Module Statistics : Local Traffic » Pools

Traffic Summary DNS Local Traffic Network Memory

Display Options

Statistics Type: Pools

Data Format: Normalized

Auto Refresh: Disabled Refresh

		Bits		Packets		Connections					
✓	Status	Pool	Pool Member	Partition / Path	In	Out	In	Out	Current	Maximum	Total
<input type="checkbox"/>	●	POOL-1		Common	0	0	0	0	0	0	0
<input type="checkbox"/>	●	POOL-2		Common	24.8K	64.3K	31	27	1	2	5
<input type="checkbox"/>	●	POOL-3		Common	0	0	0	0	0	0	0

Reset

Using Putty, open an **SSH** session to **10.10.1.103** port **22**. The **SSH** traffic should be redirected to the node **172.16.4.12** which is the router **R3**.

```

10.10.4.103 - PuTTY
login as: admin
Sent username "admin"
admin@10.10.4.103's password:

R3#sh run int fa0/0
Building configuration...

Current configuration : 115 bytes
!
interface FastEthernet0/0
 ip address 172.16.4.12 255.255.255.0
 no ip route-cache
 speed auto
 duplex auto
end

R3#
  
```

View statistics and configuration information in the Pools.

Since the node **172.16.4.12** belongs to the **POOL-3**, the number of the bits and the packets is increased.

Statistics » Module Statistics : Local Traffic » Pools

Traffic Summary | DNS | Local Traffic | Network | Memory

Display Options

Statistics Type: Pools
 Data Format: Normalized
 Auto Refresh: Disabled Refresh

	Status	Pool	Pool Member	Partition / Path	Bits		Packets		Connections		
					In	Out	In	Out	Current	Maximum	Total
<input type="checkbox"/>	●	POOL-1		Common	0	0	0	0	0	0	0
<input type="checkbox"/>	●	POOL-2		Common	0	0	0	0	0	0	0
<input type="checkbox"/>	●	POOL-3		Common	13.5K	9.4K	32	18	1	1	1

Reset

Lab 11: SNAT

Configure Auto map with Self IP

Add SNAT Auto Map to the virtual server

Local Traffic » Address Translation, SNAT List, then click **Create**

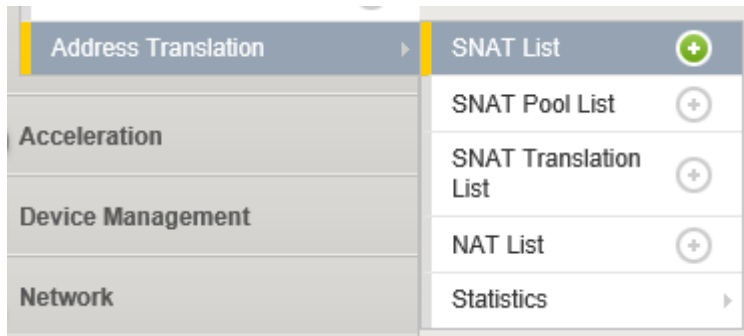

General Properties:

Name: AUTO-NAT

Configuration section:

Translation: Select Auto Map

Origin: Address List

Address List: 10.10.4.200, then click **Add**

Source Port: Preserve

VLAN / Tunnel Traffic: * All

Auto Last Hop: Default

When complete, click **Finished**

A screenshot of the F5 configuration form for SNAT List. The form is divided into two sections: 'General Properties' and 'Configuration'.
General Properties:
- Name: AUTO-NAT
- Description: (empty field)
Configuration:
- Translation: Automap (dropdown menu)
- Origin: All IPv4 Addresses (dropdown menu)
- Source Port: (empty field)
- VLAN / Tunnel Traffic: * All (dropdown menu)
- Auto Last Hop: Default (dropdown menu)
At the bottom of the form, there are three buttons: 'Cancel', 'Repeat', and 'Finished'.

General Properties

Name	AUTO-NAT
Description	

Configuration

Translation	Automap
Origin	Address List
Address List	Address/Prefix Length: 10.10.4.200 x
	<input type="button" value="Add"/> 10.10.4.200 <input type="button" value="Edit"/> <input type="button" value="Delete"/>
Source Port	Preserve
VLAN / Tunnel Traffic	* All
Auto Last Hop	Default

<input checked="" type="checkbox"/>	▲ Name	◆ Description	◆ Application	Translation	SNAT Pool	◆ Partition / Path
<input type="checkbox"/>	AUTO-NAT			Automap		Common

Configure SNAT with a Single IP

General Properties:

Name: SNAT-Single-IP

Configuration section:

Translation: Select IP Address: 172.16.4.41

Origin: Address List

Address List: 10.10.4.201, then click **Add**

Source Port: Preserve

VLAN / Tunnel Traffic: * All

Auto Last Hop: Default

When complete, click **Finished**

General Properties

Name: SNAT-Single-IP

Description:

Configuration

Translation: IP Address | 172.16.4.41

Origin: Address List

Address List: Address/Prefix Length: 10.10.4.201
 Add
 10.10.4.201
 Edit Delete

Source Port: Preserve

VLAN / Tunnel Traffic: * All

Auto Last Hop: Default

Cancel Repeat Finished

Create...

<input checked="" type="checkbox"/>	Name	Description	Application	Translation	SNAT Pool	Partition / Path
<input type="checkbox"/>	AUTO-NAT			Automap		Common
<input type="checkbox"/>	SNAT-Single-IP			172.16.4.41		Common

Delete...

Configure SNAT Pool

Local Traffic » Address Translation » SNAT Pool List, then click **Create**

General Properties section:

Name: SNAT-POOL-LIST

Member List: IP Address: 172.16.4.51, then click **Add**

IP Address: 172.16.4.52, then click **Add**

IP Address: 172.16.4.53, then click **Add**

When complete, click **Finished**

General Properties

Name: SNAT-POOL-LIST

Configuration

Member List: IP Address: 172.16.4.53
 Add
 172.16.4.51
 172.16.4.52
 172.16.4.53
 Edit Delete

Cancel Repeat Finished

		Create...	
<input checked="" type="checkbox"/>	▲ Name	↕ Application	↕ Partition / Path
<input type="checkbox"/>	SNAT-POOL-LIST		Common
Delete...			

Navigate to **Local Traffic » Address Translation, SNAT List**, then click **Create**

General Properties:

Name: SNAT-POOL

Configuration section:

Translation: Select SNAT Pool and SNAT-POOL-LIST

Origin: Address List

Address List: 10.10.4.202, then click **Add**

Source Port: Preserve

VLAN / Tunnel Traffic: * All

Auto Last Hop: Default

When complete, click **Finished**

General Properties	
Name	SNAT-Pool
Description	
Configuration	
Translation	SNAT Pool SNAT-POOL-LIST
Origin	Address List
Address List	Address/Prefix Length: 10.10.4.202
	<input type="button" value="Add"/> 10.10.4.202 <input type="button" value="Edit"/> <input type="button" value="Delete"/>
Source Port	Preserve
VLAN / Tunnel Traffic	* All
Auto Last Hop	Default
<input type="button" value="Cancel"/> <input type="button" value="Repeat"/> <input type="button" value="Finished"/>	

		Create...				
<input checked="" type="checkbox"/>	▲ Name	↕ Description	↕ Application	Translation	SNAT Pool	↕ Partition / Path
<input type="checkbox"/>	AUTO-NAT			Automap		Common
<input type="checkbox"/>	SNAT-Pool				SNAT-POOL-LIST	Common
<input type="checkbox"/>	SNAT-Single-IP			172.16.4.41		Common
Delete...						

From the external client, open a web browser, connect to <http://10.10.4.100>.
View SNAT statistics, you should see the Auto map used to translate the IP 10.10.4.200.

Display Options

Statistics Type	SNATs
Data Format	Normalized
Auto Refresh	Disabled <input type="button" value="Refresh"/>

		Bits		Packets		Connections			
<input checked="" type="checkbox"/>	▲ SNAT	↕ Partition / Path	↕ In	↕ Out	↕ In	↕ Out	↕ Current	↕ Maximum	↕ Total
<input type="checkbox"/>	AUTO-NAT	Common	45.8K	191.8K	70	80	0	4	10
<input type="checkbox"/>	SNAT-Pool	Common	0	0	0	0	0	0	0
<input type="checkbox"/>	SNAT-Single-IP	Common	0	0	0	0	0	0	0

On the external client, change the IP address to 10.10.4.201.
Still from the external client, open a web browser, connect to <http://10.10.4.100>.
View SNAT statistics, you should see the SNAT single IP used to translate the IP 10.10.4.201.

Display Options

Statistics Type	SNATs
Data Format	Normalized
Auto Refresh	Disabled <input type="button" value="Refresh"/>

		Bits		Packets		Connections			
<input checked="" type="checkbox"/>	▲ SNAT	↕ Partition / Path	↕ In	↕ Out	↕ In	↕ Out	↕ Current	↕ Maximum	↕ Total
<input type="checkbox"/>	AUTO-NAT	Common	0	0	0	0	0	0	0
<input type="checkbox"/>	SNAT-Pool	Common	0	0	0	0	0	0	0
<input type="checkbox"/>	SNAT-Single-IP	Common	36.3K	153.5K	55	62	0	4	8

On the external client, change the IP address to 10.10.4.202.
Still from the external client, open a web browser, connect to <http://10.10.4.100>.
View SNAT statistics, you should see the SNAT Pool used to translate the IP 10.10.4.202.

Display Options

Statistics Type	SNATs
Data Format	Normalized
Auto Refresh	Disabled <input type="button" value="Refresh"/>

		Bits		Packets		Connections			
<input checked="" type="checkbox"/>	▲ SNAT	↕ Partition / Path	↕ In	↕ Out	↕ In	↕ Out	↕ Current	↕ Maximum	↕ Total
<input type="checkbox"/>	AUTO-NAT	Common	0	0	0	0	0	0	0
<input type="checkbox"/>	SNAT-Pool	Common	41.2K	158.5K	63	71	1	4	9
<input type="checkbox"/>	SNAT-Single-IP	Common	0	0	0	0	0	0	0

